



# ExtremeWireless™ Antennas Specifications Guide

9036524-02 Rev AA  
May 2020



Copyright © 2020 Extreme Networks, Inc. All rights reserved.

## Legal Notice

Extreme Networks, Inc. reserves the right to make changes in specifications and other information contained in this document and its website without prior notice. The reader should in all cases consult representatives of Extreme Networks to determine whether any such changes have been made.

The hardware, firmware, software or any specifications described or referred to in this document are subject to change without notice.

## Trademarks

Extreme Networks and the Extreme Networks logo are trademarks or registered trademarks of Extreme Networks, Inc. in the United States and/or other countries.

All other names (including any product names) mentioned in this document are the property of their respective owners and may be trademarks or registered trademarks of their respective companies/owners.

For additional information on Extreme Networks trademarks, please see:

[www.extremenetworks.com/company/legal/trademarks](http://www.extremenetworks.com/company/legal/trademarks)

## Open Source Declarations

Some software files have been licensed under certain open source or third-party licenses. End-user license agreements and open source declarations can be found at:

[www.extremenetworks.com/support/policies/software-licensing](http://www.extremenetworks.com/support/policies/software-licensing)



# Table of Contents

---

Preface.....	v
Conventions.....	v
Providing Feedback to Us.....	vi
Getting Help.....	vi
Documentation and Training.....	vii
<b>External Antenna Selection and Site Preparation.....</b>	<b>8</b>
Antenna Connector Types.....	8
Antenna Selection Criteria.....	10
Antenna Location Criteria.....	13
<b>Cable Options.....</b>	<b>17</b>
<b>Antenna Compatibility Matrix.....</b>	<b>18</b>
<b>External Antenna Connectors.....</b>	<b>19</b>
AP510e external antenna connectors.....	19
AP410e external antenna connectors.....	21
AP310e external antenna connectors.....	22
AP460e external antenna connectors.....	22
<b>External Antenna Specifications and Radiation Patterns.....</b>	<b>24</b>
ML-2452-APA2-01 and ML-2452-APA2-02 Antenna Specifications and Radiation Patterns.....	24
ML-2452-HPA5-036 Antenna Specifications and Radiation Patterns.....	28
ML-2452-HPA6-01 Antenna Specifications and Radiation Patterns.....	33
ML-2452-HPAG4A6-01 Antenna Specifications and Radiation Patterns.....	36
ML-2452-HPAG5A8-01 Antenna Specifications and Radiation Patterns.....	39
ML-2452-PTA4M4-036 Antenna Specifications and Radiation Patterns.....	43
ML-2452-PNA5-01R Antenna Specifications and Radiation Patterns.....	49
ML-2452-SEC6M4-036 Antenna Specifications and Radiation Patterns.....	53
ML-2452-PNA7-01R Antenna Specifications and Radiation Patterns.....	55
AI-DQ04360S Antenna Specifications and Radiation Patterns.....	58
WS-AI-DQ05120 Antenna Specifications and Radiation Patterns.....	61
WS-AI-DE07025 Antenna Specifications and Radiation Patterns.....	65
WS-AI-DE10055 Antenna Specifications and Radiation Patterns.....	69
WS-AO-DQ04360N Antenna Specifications and Radiation Patterns.....	73
<b>Internal Antenna Radiation Patterns.....</b>	<b>77</b>
AP505i Internal Antenna Radiation Patterns.....	78
AP510i Internal Antenna Radiation Patterns.....	82
AP560i Internal Antenna Radiation Patterns.....	88
<b>Antenna Cables Specifications.....</b>	<b>94</b>
Indoor antenna cables with RP-SMA type connectors.....	94

---

Outdoor antenna cables with standard N-type plug and jack connectors.....	95
<b>Antenna Installation Information.....</b>	<b>99</b>
Antenna Installation Best Practices.....	99
Install the ML-2452-APA2-01 or ML-2452-APA2-02 Antenna.....	100
Install the ML-2452-HPA5-036 Antenna.....	101
Install the ML-2452-HPA6-01 Antenna.....	110
Install the ML-2452-HPAG4A6-01 Antenna.....	110
Install the ML-2452-HPAG5A8-01 Antenna.....	111
Install the ML-2452-PTA4M4-036 Antenna.....	114
Install the ML-2452-PNA5-01R Antenna.....	115
Install the ML-2452-SEC6M4-036 Antenna.....	122
Install the ML-2452-PNA7-01R Antenna.....	125
Install the AI-DQ04360S Antenna.....	129
Install the WS-AI-DQ05120, WS-AI-DE07025, or WS-AI-DE10055 Antenna.....	137
Install the WS-AO-DQ04360N Antenna.....	143
<b>Index.....</b>	<b>151</b>



# Preface

---

This section discusses the conventions used in this guide, ways to provide feedback, additional help, and other Extreme Networks® publications.

## Conventions





---

This section discusses the conventions used in this guide.

### Text Conventions

The following tables list text conventions that are used throughout this guide.

**Table 1: Notice Icons**

Icon	Notice Type	Alerts you to...
	General Notice	Helpful tips and notices for using the product.
	Note	Important features or instructions.
	Caution	Risk of personal injury, system damage, or loss of data.
	Warning	Risk of severe personal injury.
<b><i>New!</i></b>	New Content	Displayed next to new content. This is searchable text within the PDF.

**Table 2: Text Conventions**

Convention	Description
<code>Screen displays</code>	This typeface indicates command syntax, or represents information as it appears on the screen.
The words <b>enter</b> and <b>type</b>	When you see the word “enter” in this guide, you must type something, and then press the Return or Enter key. Do not press the Return or Enter key when an instruction simply says “type.”

**Table 2: Text Conventions (continued)**

Convention	Description
<b>[Key]</b> names	Key names are written with brackets, such as <b>[Return]</b> or <b>[Esc]</b> . If you must press two or more keys simultaneously, the key names are linked with a plus sign (+). Example: Press <b>[Ctrl]+[Alt]+[Del]</b>
<i>Words in italicized type</i>	Italics emphasize a point or denote new terms at the place where they are defined in the text. Italics are also used when referring to publication titles.

## Providing Feedback to Us

---

Quality is our first concern at Extreme Networks, and we have made every effort to ensure the accuracy and completeness of this document. We are always striving to improve our documentation and help you work better, so we want to hear from you! We welcome all feedback but especially want to know about:

- Content errors or confusing or conflicting information.
- Ideas for improvements to our documentation so you can find the information you need faster.
- Broken links or usability issues.

If you would like to provide feedback to the Extreme Networks Information Development team, you can do so in two ways:

- Use our short online feedback form at <https://www.extremenetworks.com/documentation-feedback/>.
- Email us at [documentation@extremenetworks.com](mailto:documentation@extremenetworks.com).

Please provide the publication title, part number, and as much detail as possible, including the topic heading and page number if applicable, as well as your suggestions for improvement.

## Getting Help

---

If you require assistance, contact Extreme Networks using one of the following methods:

### Extreme Portal

Search the GTAC (Global Technical Assistance Center) knowledge base, manage support cases and service contracts, download software, and obtain product licensing, training, and certifications.

### The Hub

A forum for Extreme Networks customers to connect with one another, answer questions, and share ideas and feedback. This community is monitored by Extreme Networks employees, but is not intended to replace specific guidance from GTAC.

### Call GTAC

For immediate support: 1-800-998-2408 (toll-free in U.S. and Canada) or +1 408-579-2826. For the support phone number in your country, visit: [www.extremenetworks.com/support/contact](http://www.extremenetworks.com/support/contact)

Before contacting Extreme Networks for technical support, have the following information ready:

- Your Extreme Networks service contract number and/or serial numbers for all involved Extreme Networks products
- A description of the failure
- A description of any action(s) already taken to resolve the problem
- A description of your network environment (such as layout, cable type, other relevant environmental information)
- Network load at the time of trouble (if known)
- The device history (for example, if you have returned the device before, or if this is a recurring problem)
- Any related RMA (Return Material Authorization) numbers

## Subscribing to Service Notifications

You can subscribe to email notifications for product and software release announcements, Vulnerability Notices, and Service Notifications.

1. Go to [www.extremenetworks.com/support/service-notification-form](http://www.extremenetworks.com/support/service-notification-form).
2. Complete the form with your information (all fields are required).
3. Select the products for which you would like to receive notifications.



### Note

You can modify your product selections or unsubscribe at any time.

4. Click **Submit**.

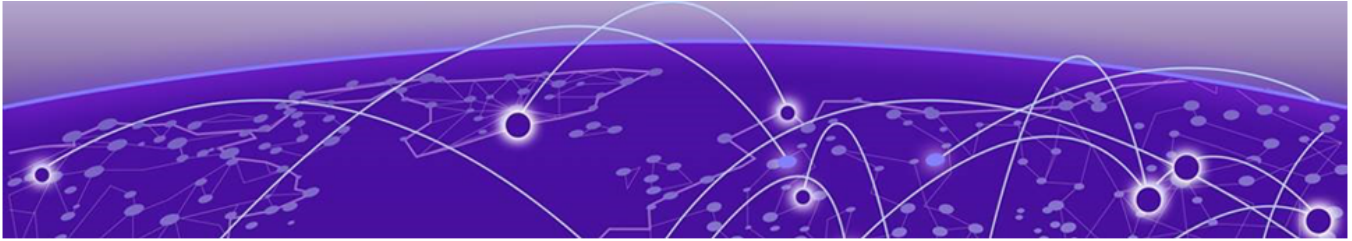
## Documentation and Training

To find Extreme Networks product guides, visit our documentation pages at:

Current Product Documentation	<a href="http://www.extremenetworks.com/documentation/">www.extremenetworks.com/documentation/</a>
Archived Documentation (for earlier versions and legacy products)	<a href="http://www.extremenetworks.com/support/documentation-archives/">www.extremenetworks.com/support/documentation-archives/</a>
Release Notes	<a href="http://www.extremenetworks.com/support/release-notes">www.extremenetworks.com/support/release-notes</a>
Hardware/Software Compatibility Matrices	<a href="https://www.extremenetworks.com/support/compatibility-matrices/">https://www.extremenetworks.com/support/compatibility-matrices/</a>
White papers, data sheets, case studies, and other product resources	<a href="https://www.extremenetworks.com/resources/">https://www.extremenetworks.com/resources/</a>

## Training

Extreme Networks offers product training courses, both online and in person, as well as specialized certifications. For more information, visit [www.extremenetworks.com/education/](http://www.extremenetworks.com/education/).



# External Antenna Selection and Site Preparation

---

[Antenna Connector Types](#) on page 8

[Antenna Selection Criteria](#) on page 10

[Antenna Location Criteria](#) on page 13

Although several antennas may work in a given environment, some will provide better coverage than others. Using the right antenna in the right location will maximize both the performance and coverage of your network. Understanding the key characteristics that describe how an antenna sends and receives radio frequency signals is critical to finding the ideal antenna for your deployment. ExtremeWireless products operate in the 2.4 GHz and 5 GHz Industrial, Scientific and Medical (ISM) bands allocated for unlicensed use.

ExtremeWireless access points support either the 802.11b/g/n/ax or the 802.11a/n/ax standard, or both. Wireless devices conforming to the 802.11b/g/n/ax standard operate in the 2.4 GHz ISM band, while 802.11a/n/ax devices operate in the 5 GHz band. The antennas in this guide are grouped according to the frequency band they support. Some antennas are designed to operate within either band. These antennas, described as dual-band, are connected to radios operating in either the 2.4 GHz or 5 GHz bands.

## Antenna Connector Types

---

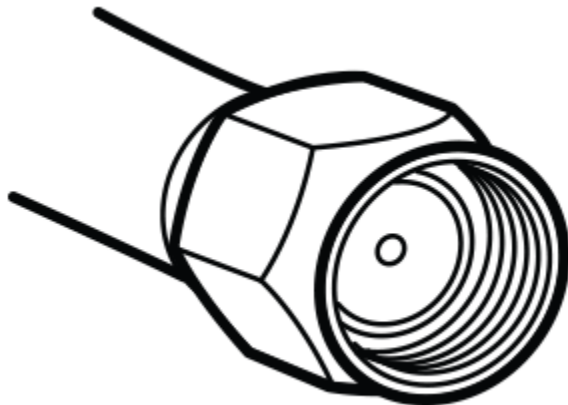
There are various types of antenna connectors that are present at one end of the indoor and outdoor antennas. The antenna connectors are used to connect the antenna to the connector on an access point. There are various types of antenna connectors, some of which are shown in the following images:



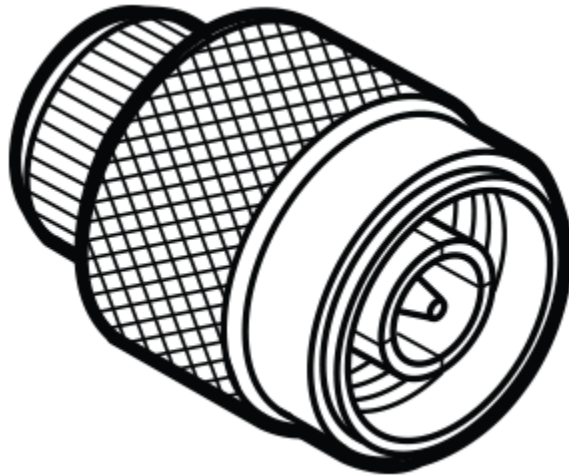


**Figure 1: RP-SMA female type antenna connector**

The following antenna connectors are used with indoor access points:



**Figure 2: Reverse polarity SMA male (RP-SMA-M) antenna connector**



**Figure 3: N-type standard male connector**

The small N-type connectors are used during indoor installations and larger connectors are used for outdoor installations.

## Antenna Selection Criteria

In addition to antenna frequency, consider the following criteria when selecting an antenna.

### Mode of use of antennas

There are antennas that can be used for indoor application or outdoor application. One important aspect of an antenna is whether it is weather sealed to protect it from environmental damages.

**Table 3: Difference between indoor and outdoor antennas**

Differences	Indoor antenna	Outdoor antenna
Use	Can only be used in indoor installations. Indoor antennas must not be used for outdoor installations.	Used for indoor as well as outdoor installations. During indoor installations, outdoor antennas can be used in freezers and coolers to handle harsh temperatures.
Connector type	RP-SMA male	N-male connector
Lightning protection	Not required	Required. But, lightning protection is not required when the antenna is installed in indoor locations.

## Antenna pattern selection criteria

Antenna pattern	Description
Omni-Directional	Signal radiates from the antenna in all directions on the horizontal plane.
Directional	Signal radiates in a specific direction, typically described as a beam of given width, expressed in degrees in the horizontal and vertical plane.

## Antenna type selection criteria

Antenna type	Description
Panel	A panel antenna is a flat antenna mounted to a wall or other vertical surface and radiates RF energy (radio waves) directionally away from the wall. They usually have gain greater than 5 dBi and are not suitable for omni-directional situations. Ideally suited for long hallways.
Patch	A patch antenna is a flat antenna mounted on the ceiling but whose pattern is omni-directional. Most of the energy goes out horizontally to the sides of the antenna and equal in all directions.
Dipole	A dipole antenna is a tubular antenna that can be either a pipe shape, a straight flexible rod or a paddle. This antenna has an omni-directional pattern when placed in a vertical position. It usually has 2 dBi of gain.
Dipole array	Essentially a dipole, a dipole array is two or more dipoles that are placed one on top of the other, requiring a longer tube to hold them. The advantage of a dipole array is that it has higher gain.
Parabolic grid	A parabolic grid antenna is a very directional, dish-like antenna. Its parabolic reflector focuses the RF energy like a flashlight. Most of the time the radiating element is a dipole, but when combined with the dish, it becomes very directional with gain up to 24 dBi. Usually used in long point-to-point systems.

Antenna type	Description
Yagi	A yagi antenna is a antenna that has an internal structure resembling that of typical antennas used for TV reception (a series of rods perpendicular to a main rod, making a triangular shape). This is a directional antenna with less gain than the PGA, typically around 13 dBi. It may be used in either point-to- point situations, or to cover a very long, narrow area in point-to-multi-point situations.
Polarized panel	A polarized panel antenna is a multi-port panel antenna with different linear polarization alignments on the different ports. Common polarization alignment orientations are Vertical/ Horizontal and Vertical/ 45°-Slant. Polarized panel antennas are useful on outdoor Line-of-Sight links, and are also used in indoor deployments for improved coverage uniformity at the expense of slightly reduced range.

## Antenna performance criteria

Antenna characteristics	Description
Frequency	The frequency band within which the antenna performs at the stated specifications.
Gain (dBi)	The relative amplification of the antenna with respect to an equivalent isotropic antenna, expressed on the decibel logarithmic scale.
Cable loss (dBi)	The signal strength loss introduced by the cable connected to the antenna expressed on the decibel logarithmic scale.
Net gain (dBi)	The resulting amplification of the antenna paired with its cable.
Polarization	The orientation of the electrical field which the antenna is optimized to receive. If the transmitting and receiving antennas are both linear polarized, then turning one 90° so that they are cross polarized will reduce the range significantly.
Voltage Standing Wave Ratio (VSWR)	Voltage Standing Wave Ratio (VSWR) is the ratio of maximum voltage to minimum voltage along the line. Expresses the degree of match between the transmission line and the terminating element (antenna). When VSWR is 1:1 the match is perfect, a VSWR of 1.5:1 corresponds to 96% power efficiency.
Azimuth 3dB beamwidth	Width of the antenna beam on the horizontal plane expressed in degrees.
Elevation 3dB beamwidth	Height of the antenna beam on the vertical plane expressed in degrees.

## Antenna Location Criteria

The following factors determine the locations where you can place the antennas relative to one another and the distances between them:

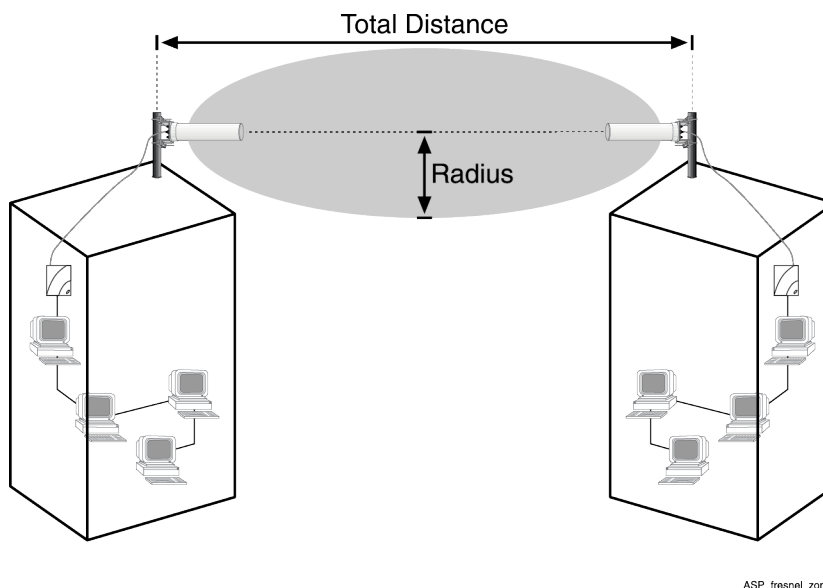
- Type of antennas
- Length of cable connecting the antenna to the access point
- Data rate required
- In a LAN-to-LAN network, the distance between the buildings
- Obstructions in the signal path
- In a wireless infrastructure network, the area around the antenna where clients need to communicate with the access point

Directional and omni-directional antennas are often installed on rooftops. The directional antenna can also be installed on the side of a building. The following sections describe the factors that affect the range of these antennas:

### Line of sight

The shape of the radio beam, defined as the Fresnel zone, is widest in the middle. The Fresnel zone is shown as the gray area between the antennas in Fresnel zone and line of sight clearance. The exact shape and width of the Fresnel zone is determined by the distance between the antenna and frequency of the radio signal.

The radius of the radio beam, shown as the lower half of the Fresnel zone, is the distance from the center of the beam outward in any direction. The length of the radius is not based on the data rate and the type of antenna.



**Figure 4: Fresnel zone and line of sight clearance**

The radius can be calculated using the following formula:

$$r = 8.675 \sqrt{D \div f}$$

Where

D = distance between the antennas in kilometers (km)

f = frequency in GHz

60% of the Fresnel zone must be clear of obstructions to be line of sight. In addition to the Fresnel zone height requirement, earth curvature may become a factor in paths longer than 2 km. The additional antenna height can be calculated using the following formula:

$$H = D^2/51499$$

Where

D = distance between the antennas in kilometers

H = height required to overcome earth curvature

**Table 4: Typical antenna height requirements - 2.4 GHz**

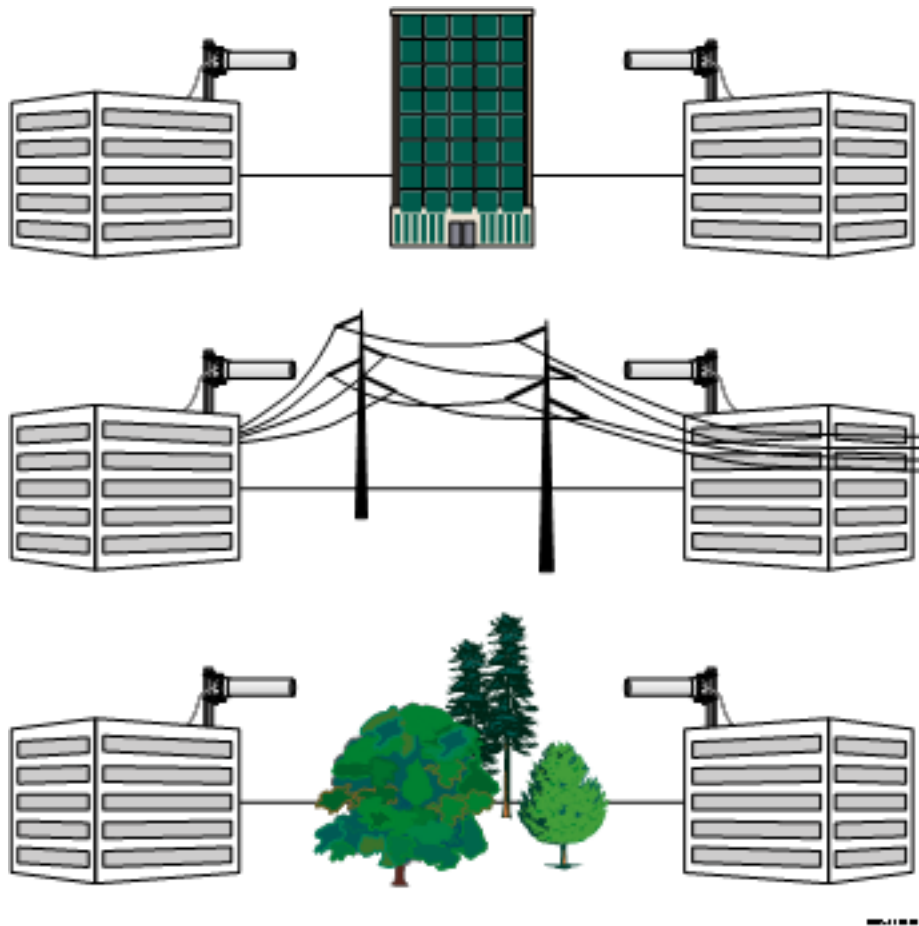
Distance between Tx and Rx antennas (km)	Fresnel zone radius (m)	Earth curvature (m)	Minimum antenna height requirements (m)
2	7.9	0.08	7.98
5	12.5	0.49	12.99
10	17.67	1.94	19.61
15	21.64	4.37	26.01
20	25	7.77	32.77
25	28	12.14	40.14
30	30.6	17.48	48.08

**Table 5: Typical antenna height requirements - 5 GHz**

Distance between Tx and Rx antennas (km)	Fresnel zone radius (m)	Earth curvature (m)	Minimum antenna height requirements (m)
2	5.22	0.08	5.3
5	8.24	0.49	8.73
10	11.67	1.94	13.61
15	14.3	4.37	18.67
20	16.5	7.77	24.27
25	18.46	12.14	30.6
30	20.22	17.48	37.7

For optimal performance, ensure that the antenna products you choose, in combination with the height of the antenna installation above ground, provide sufficient clearance to allow your antenna installation to cover the distance between the two sites.

Obstacles within the line of sight can significantly reduce the distance and performance. Obstructions include neighboring buildings, trees, and power lines, as shown in the following figure:



**Figure 5: Potential obstacles to line of sight (figure not to scale)**

## Additional antenna location requirements

This section describes other requirements to meet before installing the outdoor antennas.

- Lightning protection

A lightning rod must be placed close to the antenna mast or wall bracket. This is required to protect the antenna from direct lightning strikes.

- Grounding System

A grounding system is required when installing an outdoor antenna with an indoor or outdoor access point.

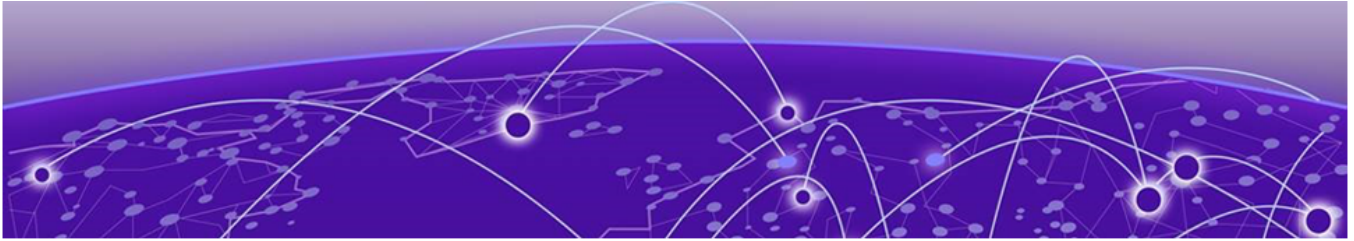
Direct earth grounding of the antenna and the lightning protector is necessary to protect the antenna from lightning and the build-up of static electricity. The access point and the lightning protector must be connected to the same earth ground using separate grounds. The antenna and the mounting structure require separate grounds to the same earth ground, using an equipotential

bonding conductor. Check with a certified antenna installer, or local electrician, to make sure the antenna is properly grounded.

**Note**

Ensure that the cable between the antenna and lightning protector is at least 3.0 ft (0.9 m) away from high-voltage or high-current cable.





## Cable Options

---

Extreme Networks offers optional low-loss, indoor and outdoor cables. The indoor cables have a RP SMA-type connector. The outdoor cables are used to connect the indoor or outdoor access points to an outdoor antenna. The outdoor cables have a standard polarity type-N plug and type-N jack.

The antennas sold by Extreme Networks come with a LMR cable attached to the antenna. The best practice is to use the cable that comes with the antenna. If the distance between the antenna and the access point is longer, then use LMR cables produced by Extreme Networks.



### Note

Determine the distance between the locations where you intend to mount the external antenna to ensure that you order the right cable length.



### Tip

The best practice is to use a smaller length LMR cable.

### Related Topics

[Antenna Cables Specifications](#) on page 94



# Antenna Compatibility Matrix

**Table 6: External antenna compatibility matrix**

Type	External antenna	Indoor access point			Outdoor access point
		AP510e	AP410e	AP310e	AP460e
Indoor	<a href="#">WS-AI-DQ05120</a> (30702)	✓	✓	✓	✗
	<a href="#">WS-AI-DE07025</a> (30705)	✓	✓	✓	✗
	<a href="#">WS-AI-DE10055</a> (30707)	✓	✓	✓	✗
	<a href="#">ML-2452-PTA4M4-036</a>	✓	✓	✓	✗
	<a href="#">ML-2452-SEC6M4-036</a>	✓	✓	✓	✗
	<a href="#">ML-2452-APA2-01</a>	✓	✓	✓	✗
	<a href="#">ML-2452-APA2-02</a>	✓	✓	✓	✗
	<a href="#">ML-2452-HPA5-036</a>	✓	✓	✓	✗
	<a href="#">AI-DQ04360S</a>	✓	✓	✓	✗
Outdoor	<a href="#">ML-2452-HPAG4A6-01</a>	✓	✓	✓	✓
	<a href="#">ML-2452-PNA5-01R</a>	✓	✓	✓	✓
	<a href="#">ML-2452-HPAG5A8-01</a>	✓	✓	✓	✓
	<a href="#">ML-2452-PNA7-01R</a>	✓	✓	✓	✓
	<a href="#">ML-2452-HPA6-01</a>	✗	✗	✗	✓
	<a href="#">WS-AO-DQ04360N</a> (30724)	✗	✗	✗	✓

Key	Description
✓	Compatible
✗	Not compatible



# External Antenna Connectors

---

The "e" model access points support external antennas. For legacy access points, refer to [Enterprise Wireless LAN Antenna Specification Guide](#) to determine if your access point supports external antennas.

The following access points support external antennas:

- AP510e
- AP410e
- AP310e
- AP460e

## AP510e external antenna connectors

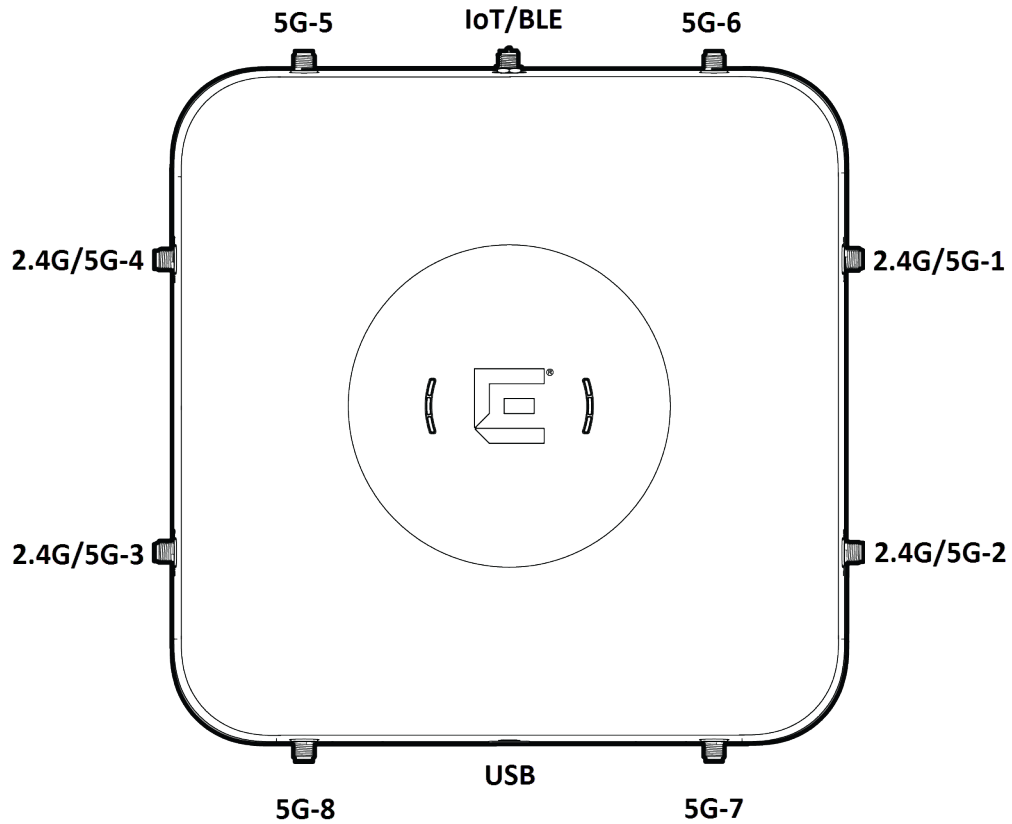
---

The AP510e access point is an indoor ceiling mount model access point with external antenna connectors. The antenna connector is a reverse polarity SMA (RP-SMA) female type connector, and uses both indoor and outdoor antennas.



### Note

If you are using any of the N-plug antenna on the access point, then you need a jumper cable to convert the N-plug antenna to a RP-SMA connector in order to attach it to the access point.



**Figure 6: AP510e external antenna configuration**

**Table 7: AP510e antenna configuration**

Software mode	Radio 1	Radio 2	Antenna ports 1, 2, 3, 4	Antenna ports 5, 6, 7, 8
Mode 1	2.4 GHz	5 GHz	Dual-band 2.4/5 GHz	None
Mode 2	Band unlocked sensor	5 GHz	Dual-band 2.4/5 GHz	5 GHz
Mode 3	5 GHz	5 GHz	5 GHz	5 GHz

**Table 8: AP510e BLE antenna information**

Wi-Fi	Part number	Brand	Model name	Description
Panel	ML-2452-PNA7-01R	Extreme	ML-2452-PNA7-01R	2.4G omni and directional support antenna
Omni	ML-2499-HPA8-01	Extreme	ML-2499-HPA8-01	2.4G omni and directional support antenna



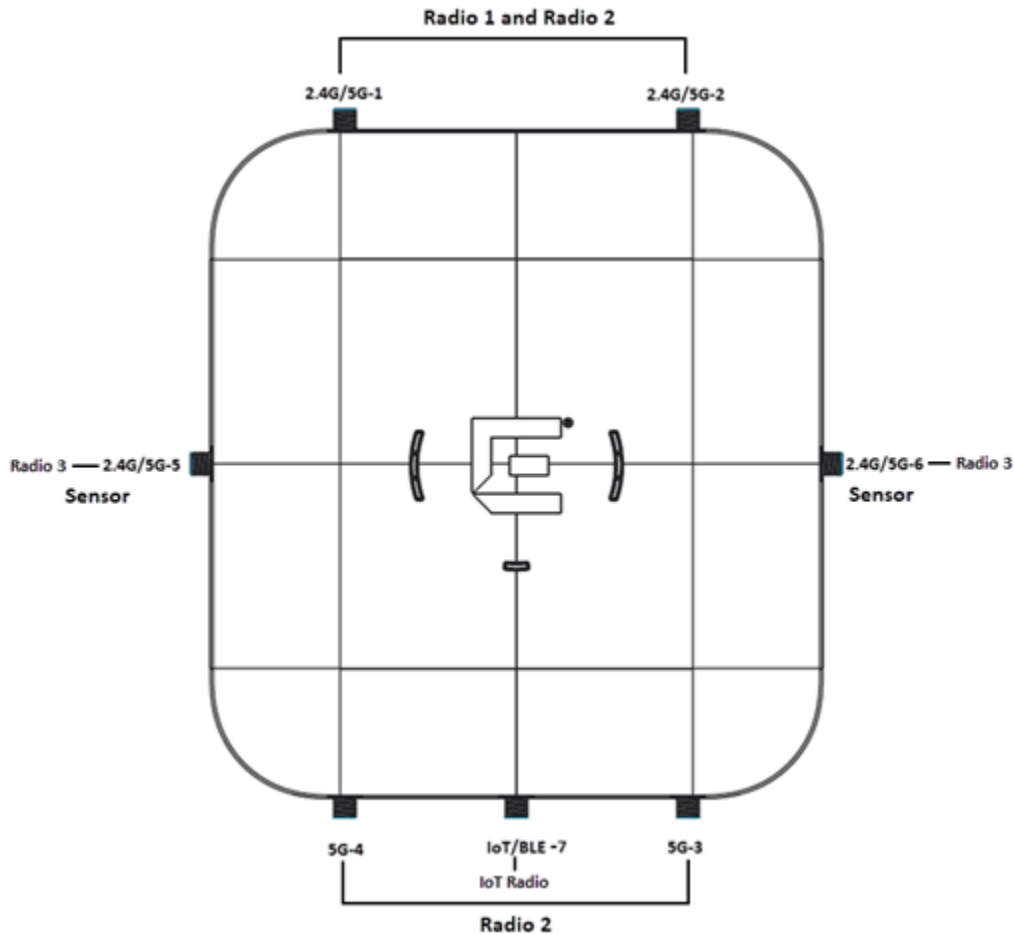
**Note**

The BLE internal antenna is used if no BLE antenna connector is attached to the port.

You may also use any other antenna with lesser gain than 2.4G omni and directional antennas as BLE antenna.

## AP410e external antenna connectors

The AP410e access point is an indoor model access point with external antenna connectors. The access point has six external RPSMA antenna connectors and one RPSMA BLE connector.



**Figure 7: AP410e external antennas**



**Note**

The sensor and the BLE antennas come with dust caps on them. Do not remove the dust cap until you need to install the antennas.

**Antenna socket radio mapping information**

- Radio 1 (R1) - antennas 1 and 2
- Radio 2 (R2) - antennas 1, 2, 3, and 4
- Radio 3 (R3) - antennas 5 and 6
- IoT radio - antenna 7 (IoT or BLE antenna)

## AP310e external antenna connectors

The AP310e access point is an indoor model access point with external antenna connectors. The access point has four external RPSMA antenna connectors and one RPSMA BLE connector.



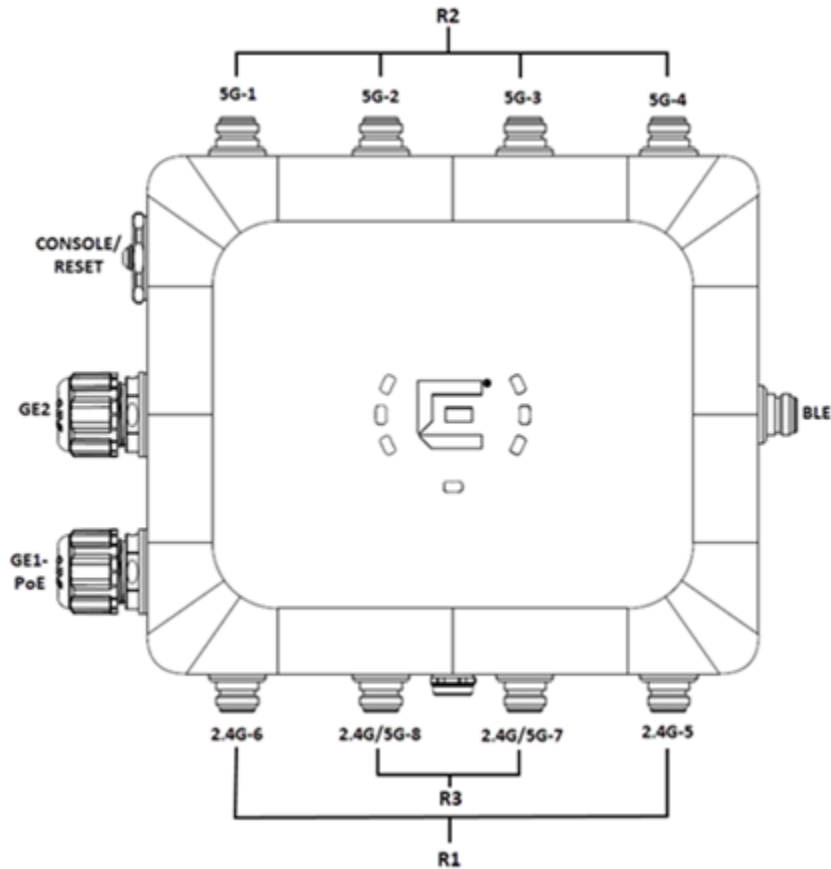
**Figure 8: AP310e access point external antenna connectors**

Antenna socket radio mapping information

- Radio 1 (R1) - antennas 1 and 2
- Radio 2 (R2) - antennas 3 and 4
- IoT radio - BLE antenna

## AP460e external antenna connectors

The AP460e access point is an outdoor model access point with external antenna connectors. The antenna connector is a standard N-type connector, and uses only outdoor antennas.



**Figure 9: AP460e external antenna connectors**

Antenna socket radio mapping information

- Radio 1 (R1) – antennas 5 and 6
- Radio 2 (R2) – antennas 1, 2, 3, and 4
- Radio 3 (R3) – antennas 7 and 8

The 2.4G and 5G-8 and the 2.4G and 5G-7 are sensor antenna ports.



**Note**

The internal BLE is always used unless you attach an antenna to the BLE antenna connector.



**Note**

The BLE antenna port and the sensor antenna ports come with dust caps installed on them. Do not remove the dust caps until you need to install the antennas.



# External Antenna Specifications and Radiation Patterns

---

[ML-2452-APA2-01 and ML-2452-APA2-02 Antenna Specifications and Radiation Patterns](#) on page 24

[ML-2452-HPA5-036 Antenna Specifications and Radiation Patterns](#) on page 28

[ML-2452-HPA6-01 Antenna Specifications and Radiation Patterns](#) on page 33

[ML-2452-HPAG4A6-01 Antenna Specifications and Radiation Patterns](#) on page 36

[ML-2452-HPAG5A8-01 Antenna Specifications and Radiation Patterns](#) on page 39

[ML-2452-PTA4M4-036 Antenna Specifications and Radiation Patterns](#) on page 43

[ML-2452-PNA5-01R Antenna Specifications and Radiation Patterns](#) on page 49

[ML-2452-SEC6M4-036 Antenna Specifications and Radiation Patterns](#) on page 53

[ML-2452-PNA7-01R Antenna Specifications and Radiation Patterns](#) on page 55

[AI-DQ04360S Antenna Specifications and Radiation Patterns](#) on page 58

[WS-AI-DQ05120 Antenna Specifications and Radiation Patterns](#) on page 61

[WS-AI-DE07025 Antenna Specifications and Radiation Patterns](#) on page 65

[WS-AI-DE10055 Antenna Specifications and Radiation Patterns](#) on page 69

[WS-AO-DQ04360N Antenna Specifications and Radiation Patterns](#) on page 73

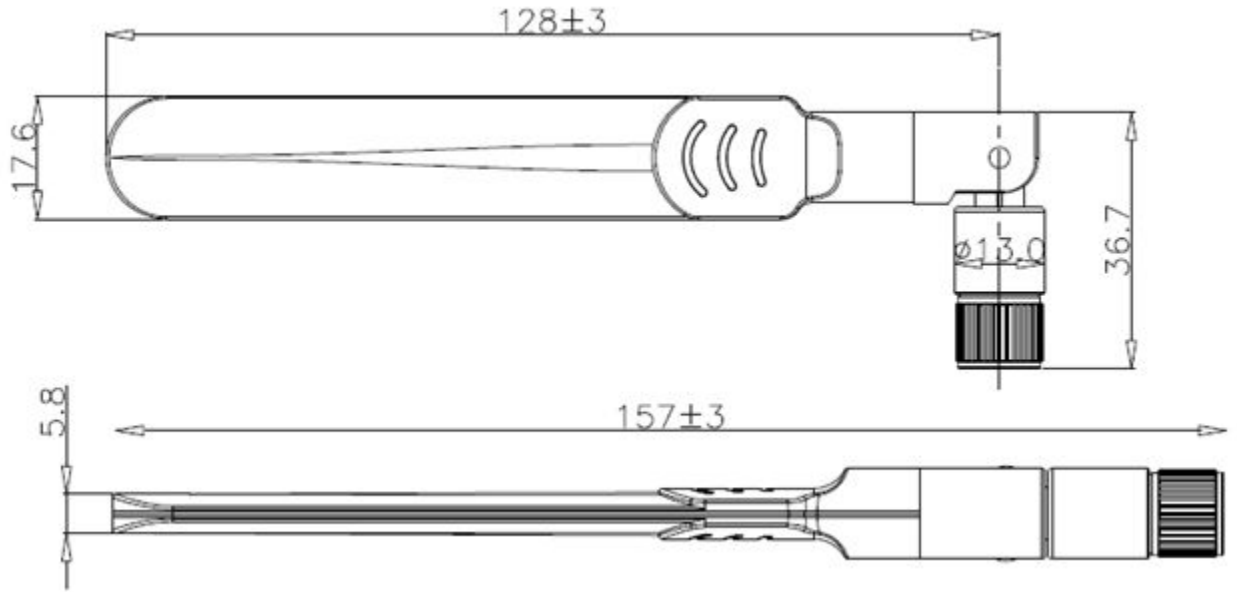
The following section lists the specifications and radiation patterns for the external antennas used with ExtremeWireless indoor access points.

## ML-2452-APA2-01 and ML-2452-APA2-02 Antenna Specifications and Radiation Patterns

---

The ML-2452-APA2-01 and ML-2452-APA2-02 are both dipole, dual-band RP-SMA plug connector antennas. The only difference between the antennas is the color. The ML-2452-APA2-01 is a black color antenna whereas the ML-2452-APA2-02 antenna is a white color antenna.





**Figure 10: ML-2452-APA2-01 and ML-2452-APA2-02 antenna**

**Table 9: ML-2452-APA2-01 and ML-2452-APA2-02 antenna technical specifications**

Parameter	Performance
Maximum power	1 watt
Polarization	Linear, vertical
Nominal impedance	50 Ω
VSWR	2.4-2.5 GHz: ≤ 1.92 5.1-5.8 GHz: ≤ 1.92
Radome material	Acrylonitrile butadiene styrene (ABS) plastic
Cable	RG-178
Mounting method	Direct-attach to the access point

**Table 10: ML-2452-APA2-01 and ML-2452-APA2-02 antenna electrical specifications**

Part number	Frequency range	Typical gain	Peak gain	Azimuth beamwidth	Elevation beamwidth	Connector
ML-2452-APA2-01 and	2.4-2.5 GHz	2.73 dBi	3.04 dBi	360°	48°	RP-SMA plug
	5.1-5.4 GHz	4.19 dBi	4.30 dBi	360°	28°	

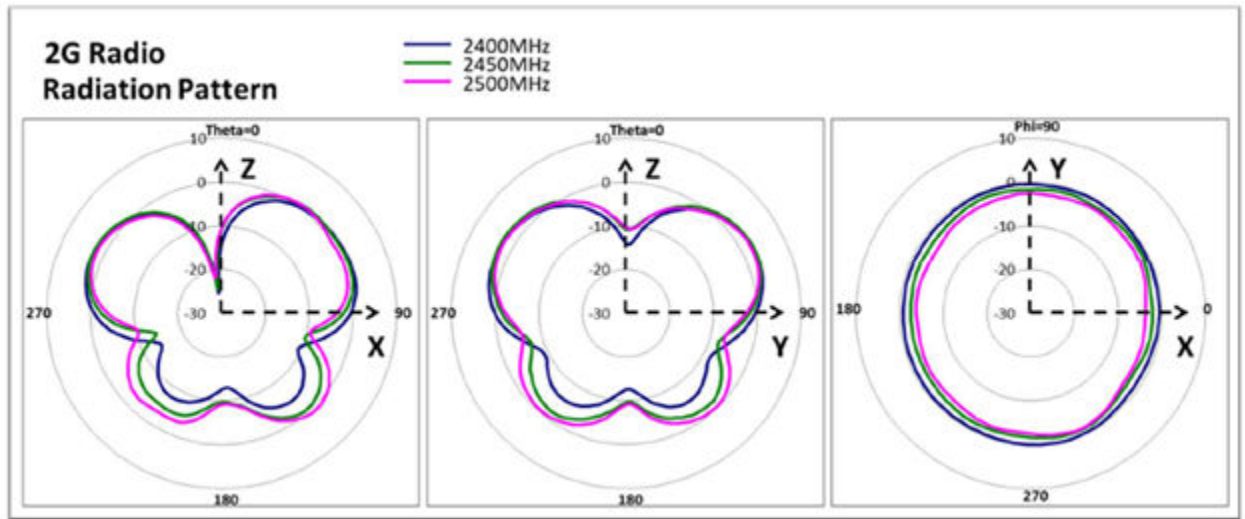
**Table 10: ML-2452-APA2-01 and ML-2452-APA2-02 antenna electrical specifications (continued)**

Part number	Frequency range	Typical gain	Peak gain	Azimuth beamwidth	Elevation beamwidth	Connector
ML-2452-APA2-02	5.5–5.7 GHz	4.64 dBi	4.96 dBi	360°	28°	
	5.7–5.8 GHz	4.95 dBi	4.96 dBi	360°	28°	

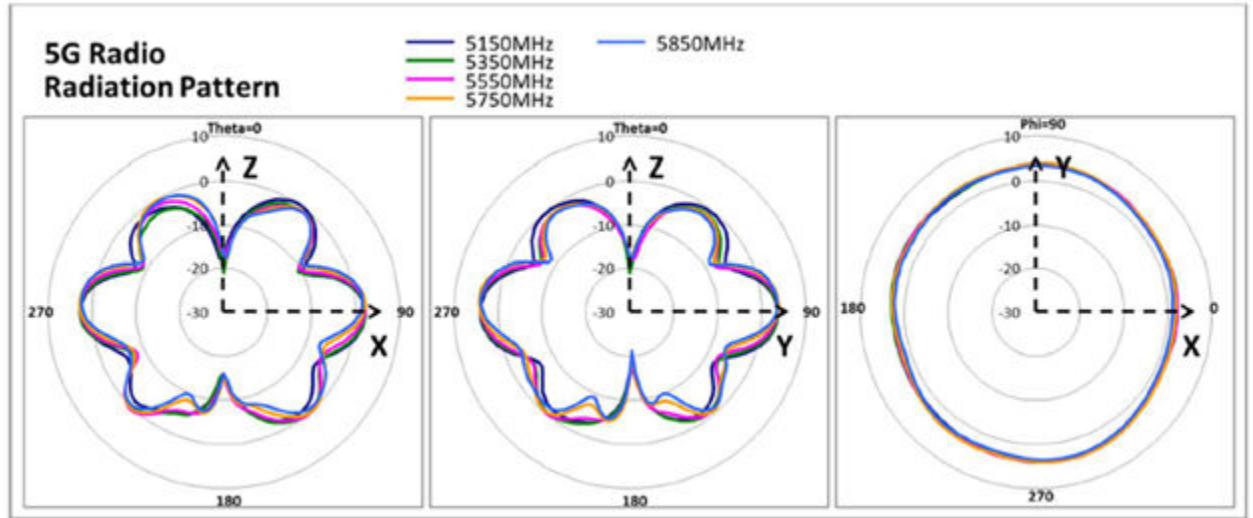
**Table 11: ML-2452-APA2-01 and ML-2452-APA2-02 mechanical specifications**

Dimensions	Weight	Temperature range
157.0 × 17.6 × 5.8 mm	0.03 lb (0.01 kg)	Storage temperature: -10°C to +70°C (-14°F to +158°F) Operating temperature: -10°C to +60°C (-14°F to +140°F)

ML-2452-APA2-01 and ML-2452-APA2-02 antenna radiation patterns



**Figure 11: 2G radio radiation pattern**

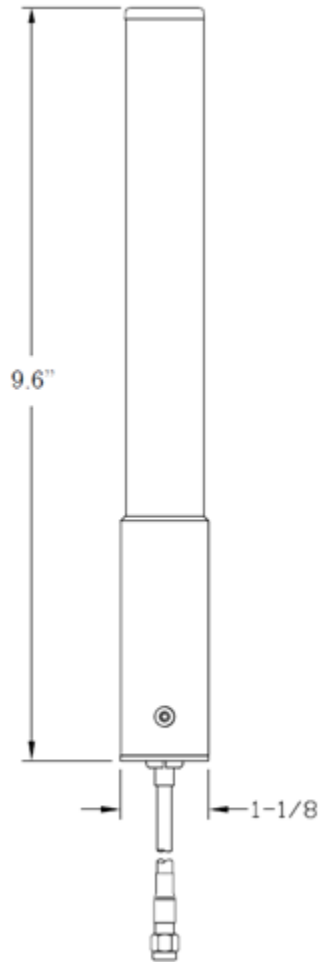


**Figure 12: 5G radio radiation pattern**

Related Topics

[Install the ML-2452-APA2-01 or ML-2452-APA2-02 Antenna](#) on page 100

## ML-2452-HPA5-036 Antenna Specifications and Radiation Patterns



**Figure 13: ML-2452-HPA5-036 antenna**

**Table 12: ML-2452-HPA5-036 antenna technical specifications**

Parameter	Performance
Maximum power	10 watts
Polarization	Linear, vertical
Nominal impedance	50 $\Omega$
VSWR	2:1
Radome material	Polycarbonate

**Table 12: ML-2452-HPA5-036 antenna technical specifications (continued)**

Parameter	Performance
Cable	36-inches RG-58 plenum-rated cable
Mounting method	Beam, ceiling, or mast mount

**Table 13: ML-2452-HPA5-036 antenna electrical specifications**

Part number	Frequency range	Typical gain	Peak gain	Azimuth beamwidth	Elevation beamwidth	Connector
ML-2452-HPA5-036	2.4-2.5 GHz	With cable: 2.1 dBi Without cable: 2.9 dBi	3.9 dBi	360°	44°	RP-SMA plug
	5.1-5.9 GHz	With cable: 3.8 dBi Without cable: 4.9 dBi	5.7 dBi		18°	

**Table 14: ML-2452-HPA5-036 antenna mechanical specifications**

Dimensions	Weight	Temperature range
25.4 mm × 245.5 mm	0.30 lb (0.14 kg)	Storage temperature: -40°C to +85°C (-40°F to +185°F) Operating temperature: -30°C to +70°C (-22°F to +158°F)

ML-2452-HPA5-036 antenna radiation patterns

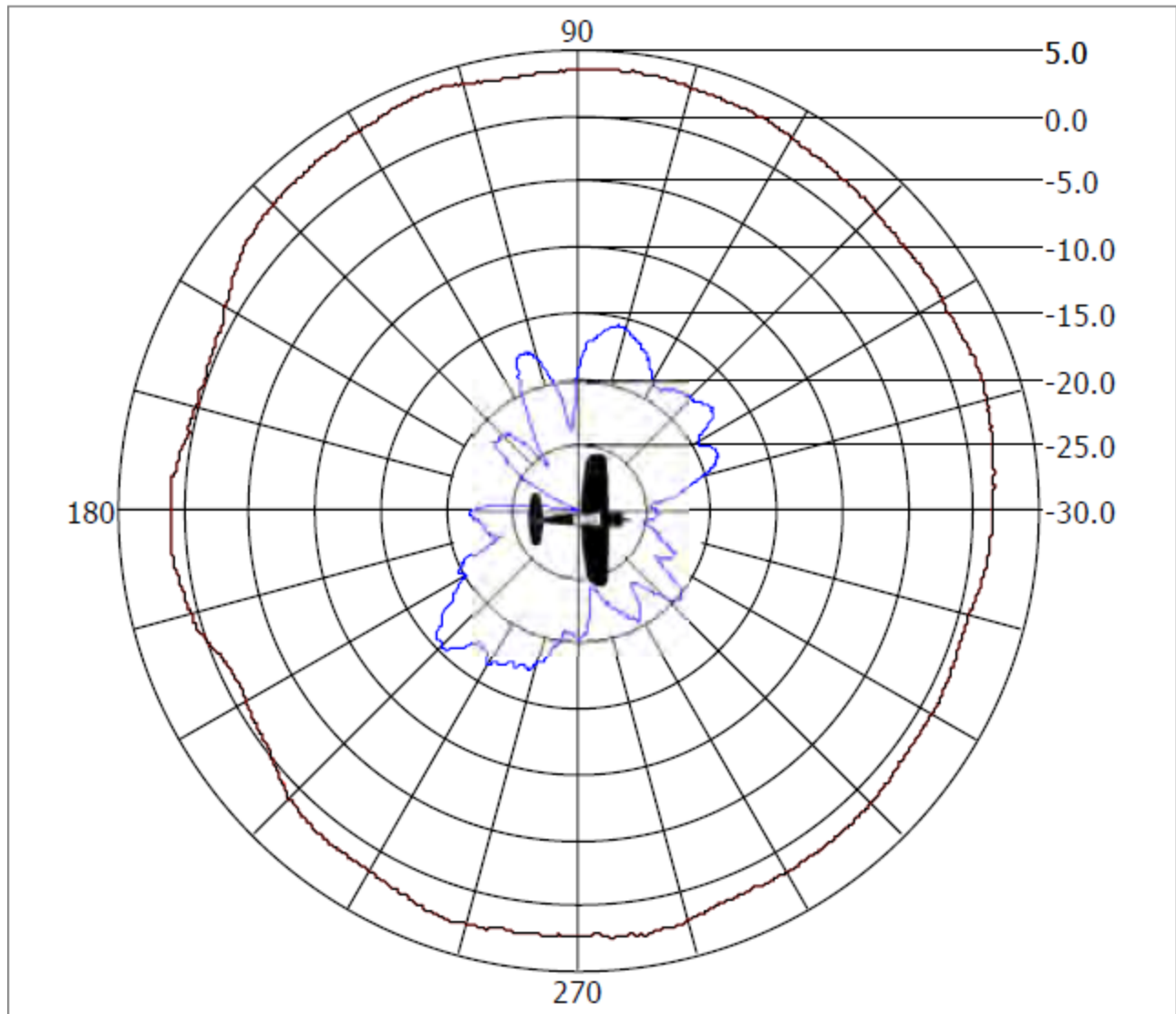


Figure 14: 2.4 GHz azimuth pattern

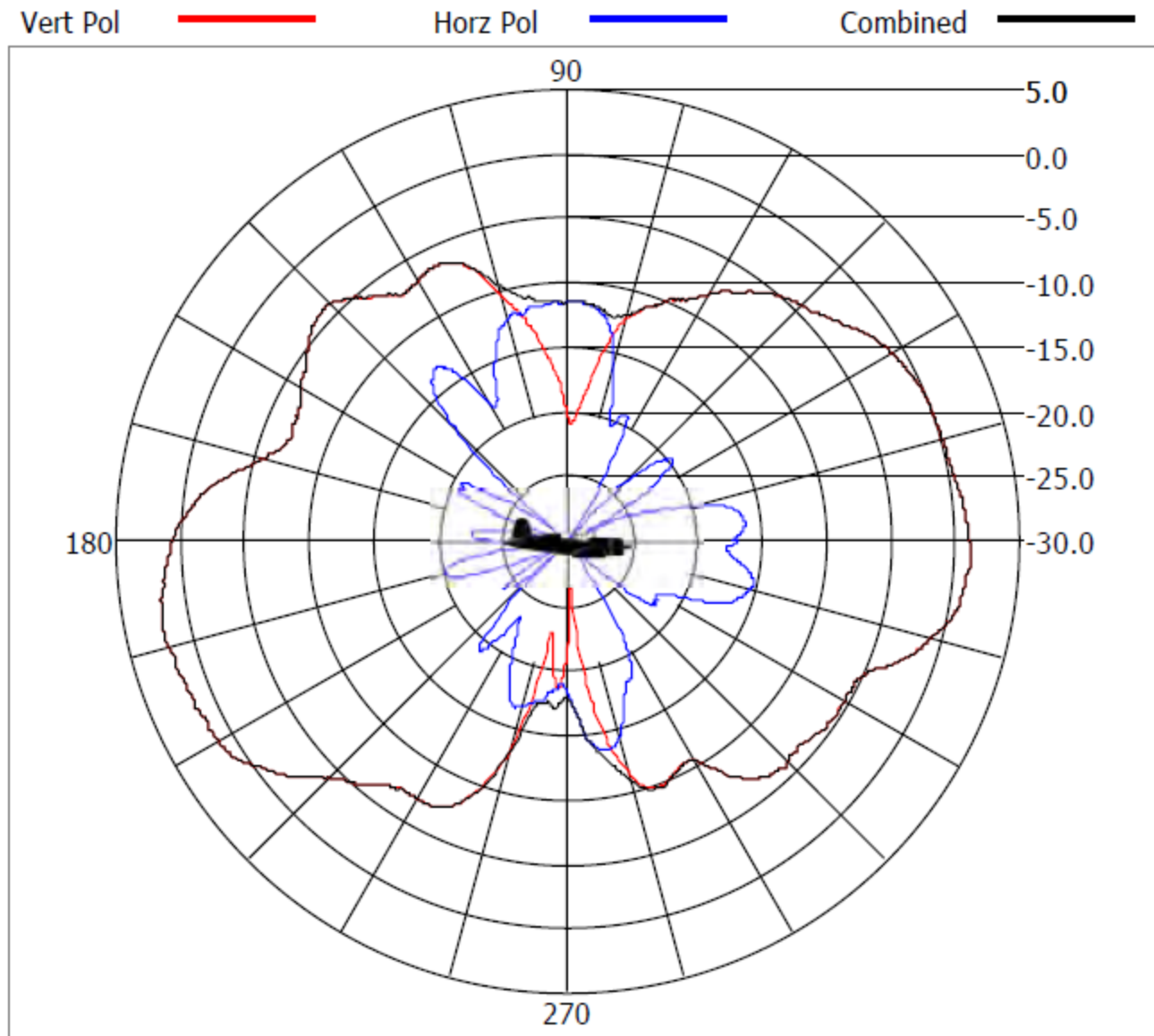
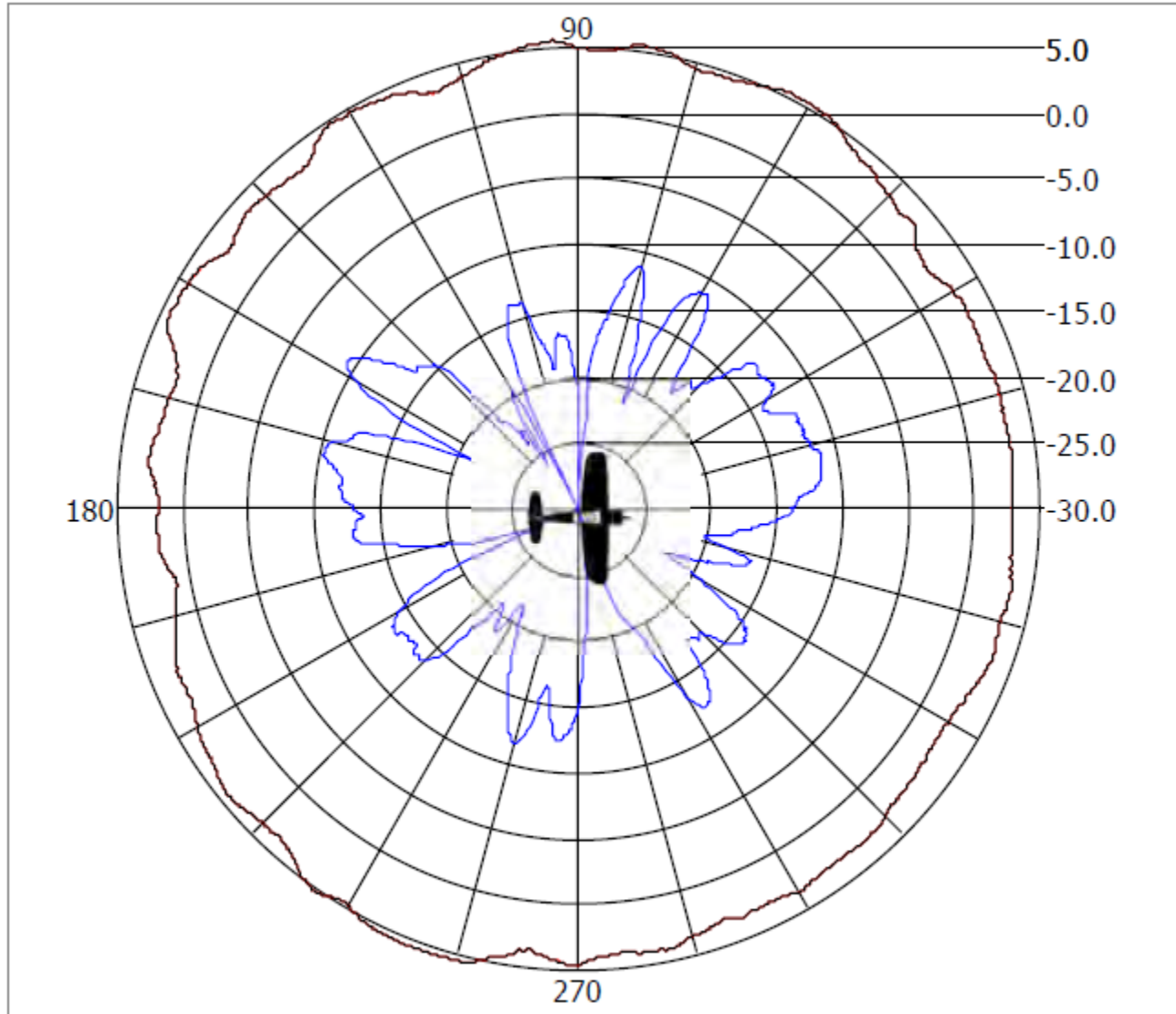
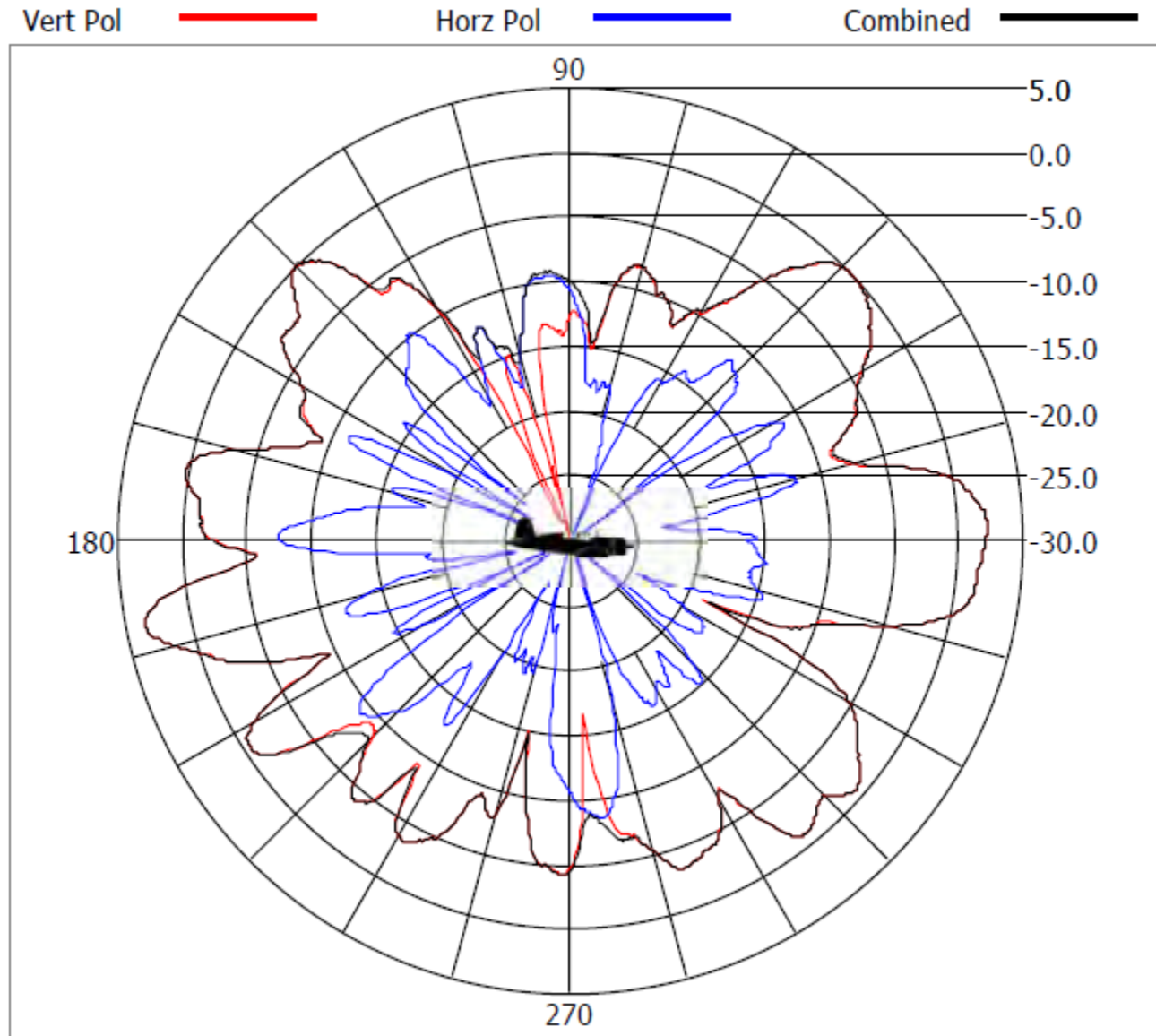


Figure 15: 2.4 GHz elevation pattern



**Figure 16: 5.6 GHz azimuth pattern**





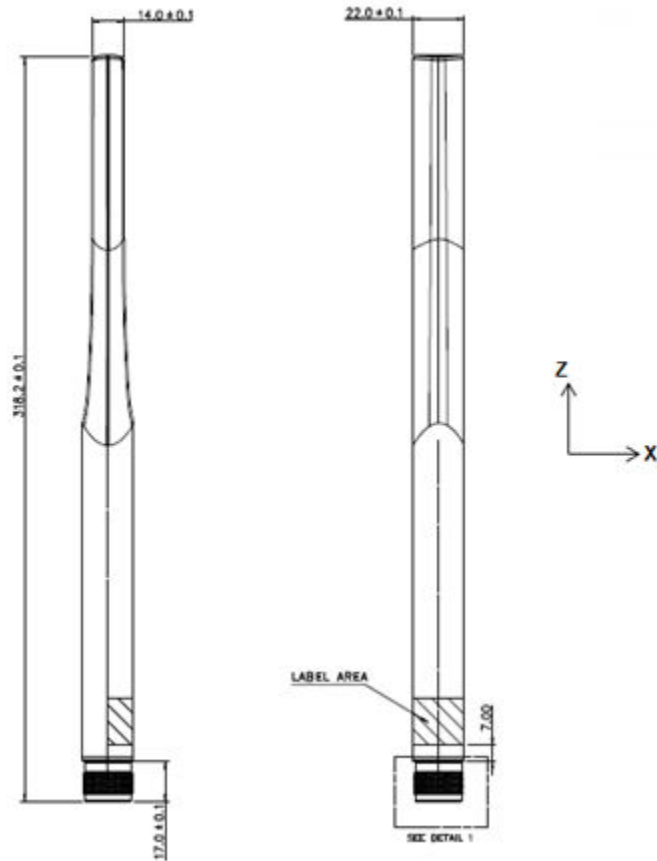
**Figure 17: 5.6 GHz elevation pattern**

Related Topics

[Install the ML-2452-HPA5-036 Antenna](#) on page 101

## ML-2452-HPA6-01 Antenna Specifications and Radiation Patterns

The ML-2452-HPA6-01 is a four feed, dual band outdoor antenna with a standard N-type plug connector.



**Figure 18: ML-2452-HPA6-01 antenna**

**Table 15: ML-2452-HPA6-01 antenna technical specifications**

Item	Description
Polarization	Dipole
VSWR	<2.0
Nominal impedance	50 Ω
Radome material	PC1110U plastic
Cable	RG-178
Mounting method	Direct attach

**Table 16: ML-2452-HPA6-01 antenna electrical specifications**

Part number	Frequency range	Typical gain	Peak gain	Azimuth bandwidth	Elevation bandwidth	Connector
	2.4 GHz - 2.5 GHz	1.1 dBi	5.3 dBi	360°	100°	N-type plug

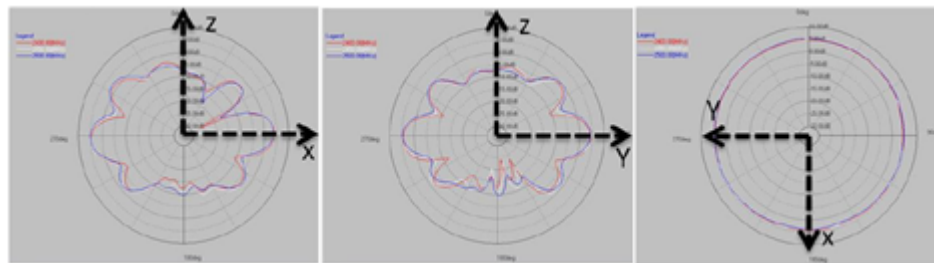
**Table 16: ML-2452-HPA6-01 antenna electrical specifications (continued)**

Part number	Frequency range	Typical gain	Peak gain	Azimuth bandwidth	Elevation bandwidth	Connector
ML-2452-HPA6-01	5.1 GHz – 5.9 GHz	2.5 dBi	6.1 dBi	360°	30°	

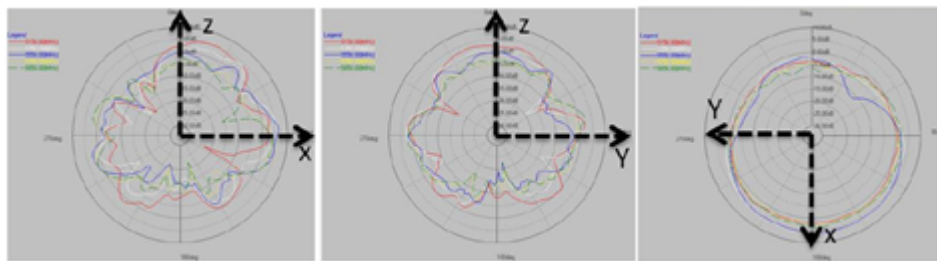
**Table 17: ML-2452-HPA6-01 antenna mechanical specifications**

Dimensions	Weight	Temperature range
318.20 mm × 22 mm	0.235 lbs (0.107 kg)	Storage and operational temperature: -40°C to +85°C (-40°F to +185°F)

ML-2452-HPA6-01 antenna radiation patterns



**Figure 19: 2.4 GHz antenna pattern**

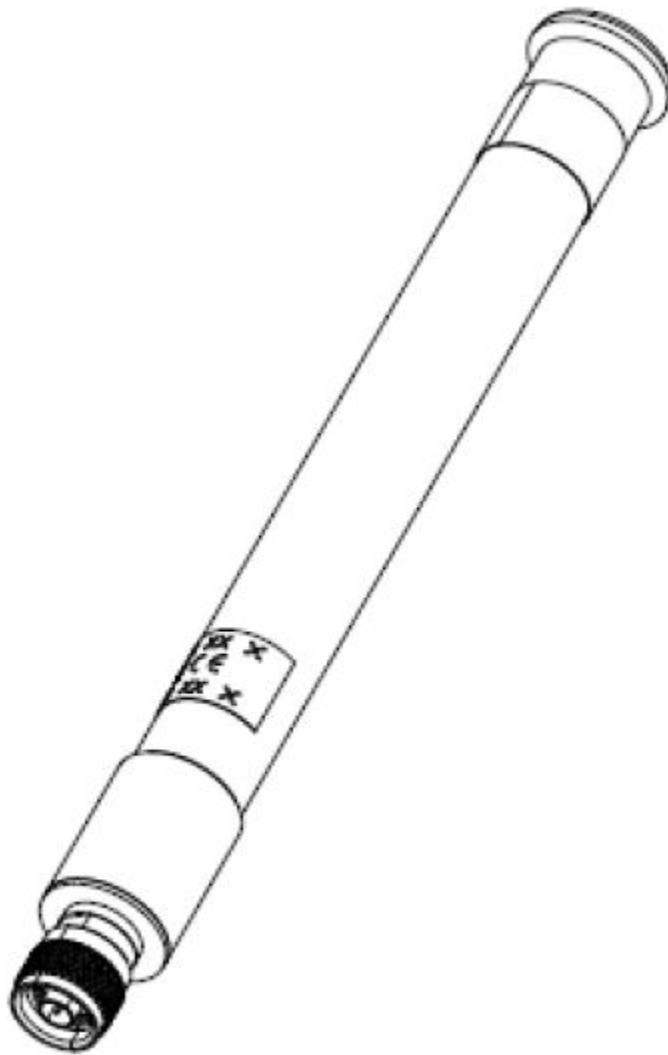
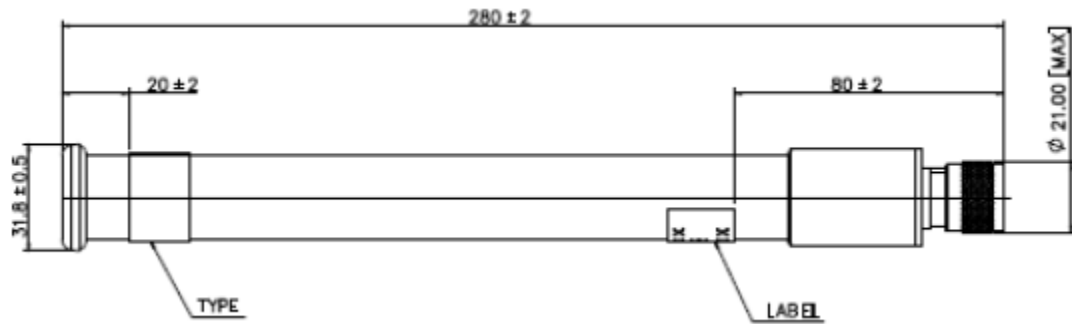


**Figure 20: 5 GHz antenna pattern**

Related Topics

[Install the ML-2452-HPA6-01 Antenna](#) on page 110

## ML-2452-HPAG4A6-01 Antenna Specifications and Radiation Patterns



**Figure 21: ML-2452-HPAG4A6-01 antenna**

**Table 18: ML-2452-HPAG4A6-01 technical specifications**

Parameter	Performance
Polarization	Linear, vertical
Nominal impedance	50 $\Omega$

**Table 18: ML-2452-HPAG4A6-01 technical specifications (continued)**

Parameter	Performance
VSWR	2.4 GHz – 2.5 GHz: 2 5.1 GHz – 5.9 GHz: 2
Radome material	Polycarbonate (PC) plastic
Cable	N/A
Mounting method	Direct attach Pole attach using the pole mounting kit

**Table 19: ML-2452-HPAG4A6-01 electrical specifications**

Part number	Frequency range	Typical gain	Peak gain	Azimuth beamwidth	Elevation beamwidth	Connector
ML-2452- APAG4A6-01	2.4 GHz – 2.5 GHz	3.0 dBi	4.0 dBi	360°	53°–56°	Standard N-plug
	5.1 GHz – 5.9 GHz	6.0 dBi	7.3 dBi	360°	18°–22°	

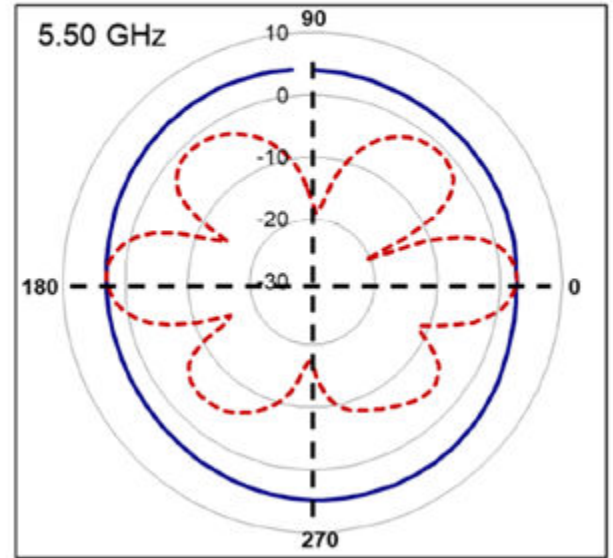
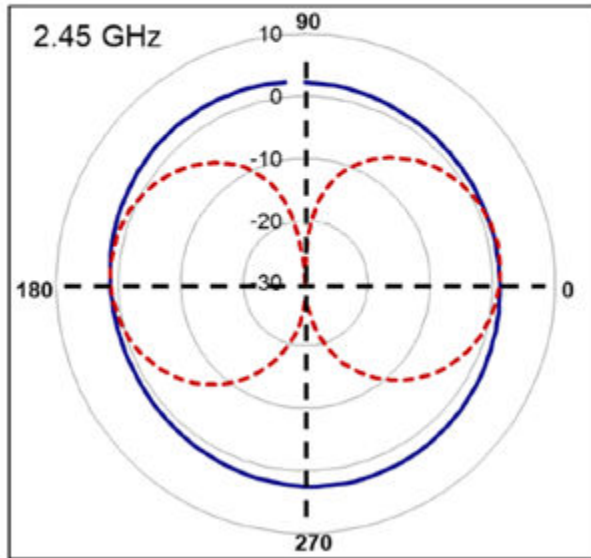
**Table 20: ML-2452-HPAG4A6-01 mechanical specifications**

Wind rating	Dimensions	Weight	Temperature range
134 mph	280.2 × 24.8 mm	0.31 lb (0.14 kg)	Storage temperature: –40°C to +80°C (–40°F to +176°F)

## ML-2452-HPAG4A6-01 antenna radiation patterns

Cut: Az/EI  
Pol: Vertical

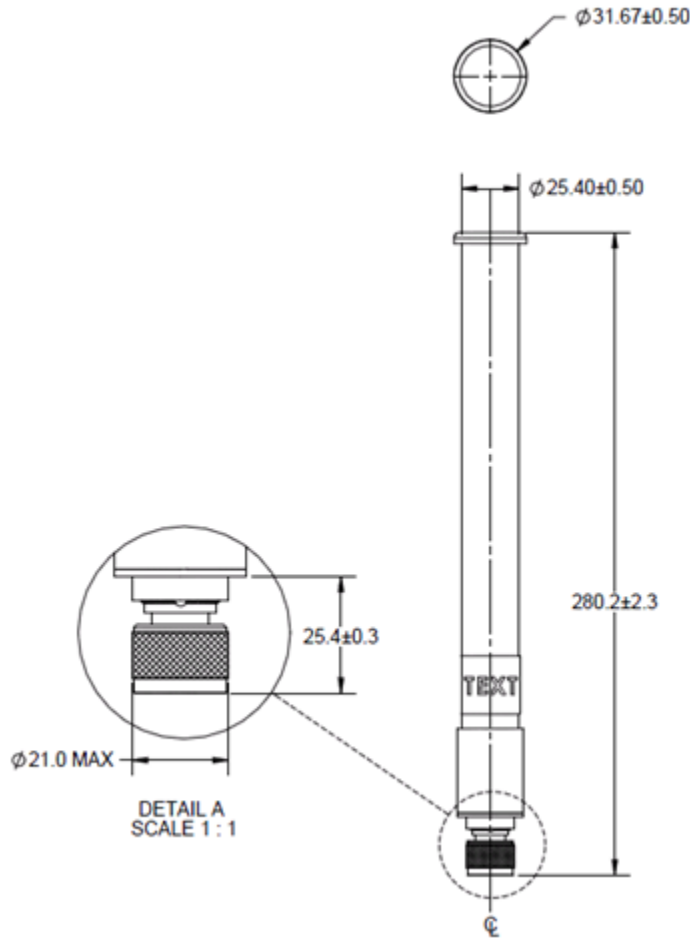
Az - solid line  
EI - broken line



Related Topics

[Install the ML-2452-HPAG4A6-01 Antenna](#) on page 110

## ML-2452-HPAG5A8-01 Antenna Specifications and Radiation Patterns



**Figure 22: ML-2452-HPAG5A8-01 antenna**

**Table 21: ML-2452-HPAG5A8-01 antenna technical specifications**

Parameter	Performance
Maximum power	10 watts
Polarization	Vertical
Nominal impedance	50 $\Omega$
VSWR	<ul style="list-style-type: none"> <li>2.4 GHz - 2.5 GHz: 2</li> <li>4.9 GHz - 5.1 GHz: 2.3</li> <li>5.1 GHz - 5.9 GHz: 2</li> </ul>

**Table 21: ML-2452-HPAG5A8-01 antenna technical specifications (continued)**

Parameter	Performance
Radome material	Polycarbonate (PC)
Mounting method	Direct mount Pole mount using pole mount kit

**Table 22: ML-2452-HPAG5A8-01 antenna electrical specifications**

Part number	Frequency range	Typical gain	Peak gain	Azimuth bandwidth	Elevation beamwidth	Connector
ML-2452-HPAG5A8-01	2.4 GHz - 2.5 GHz	4.0 dBi	4.7 dBi	360°	28°	Standard N-plug
	4.9 GHz - 5.1 GHz	6.9 dBi	7.1 dBi	360°	17°	
	5.1 GHz - 5.9 GHz	7.5 dBi	8.0 dBi	360°	15°	

**Table 23: ML-2452-HPAG5A8-01 antenna mechanical specifications**

Wind rating	Dimension	Weight	Temperature
134 mph	280.2 × 24.8 mm	0.33 lb (0.15 kg)	Storage temperature: -40°C to +85°C (-40°F to +185°F)  Operating temperature: -30°C to +70°C (-22°F to +158°F)



ML-2452-HPAG5A8-01 antenna radiation patterns

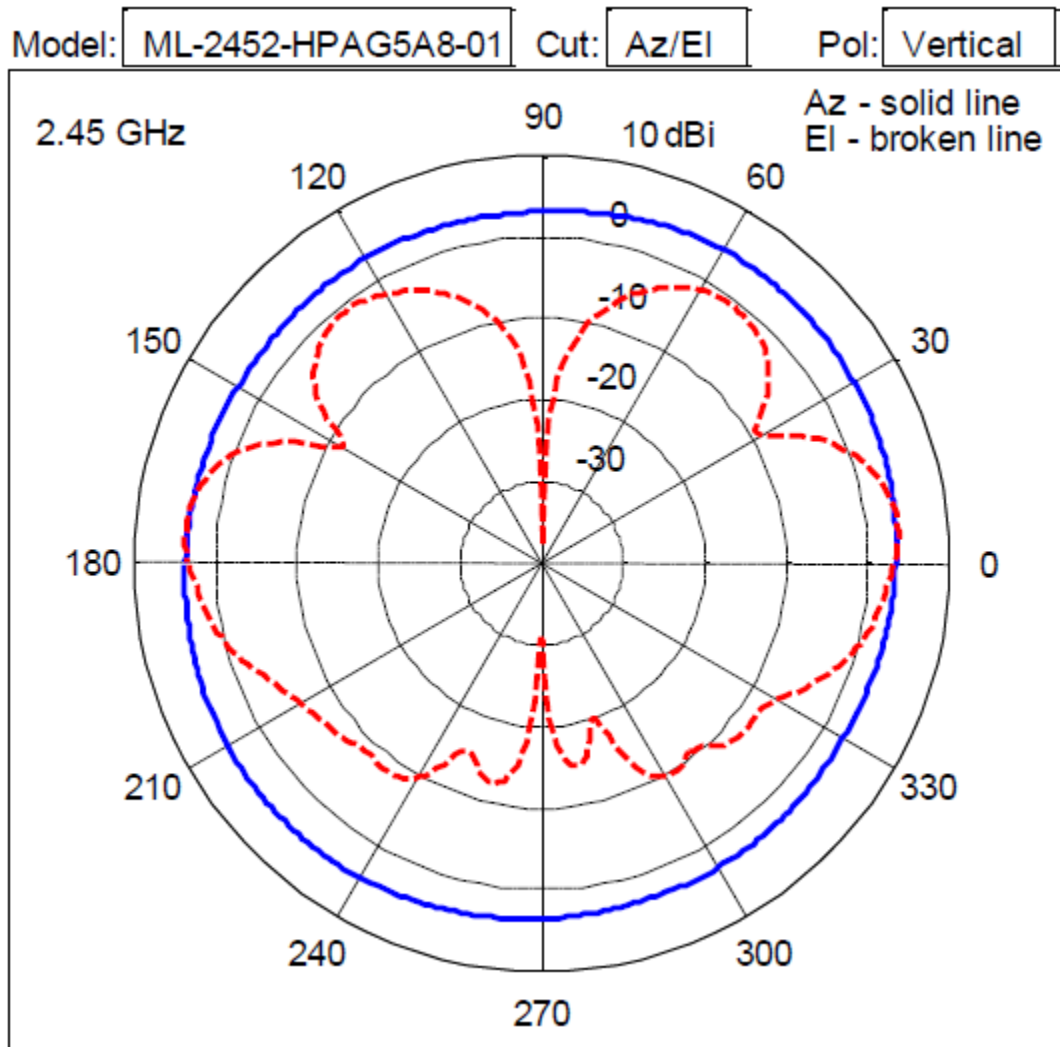
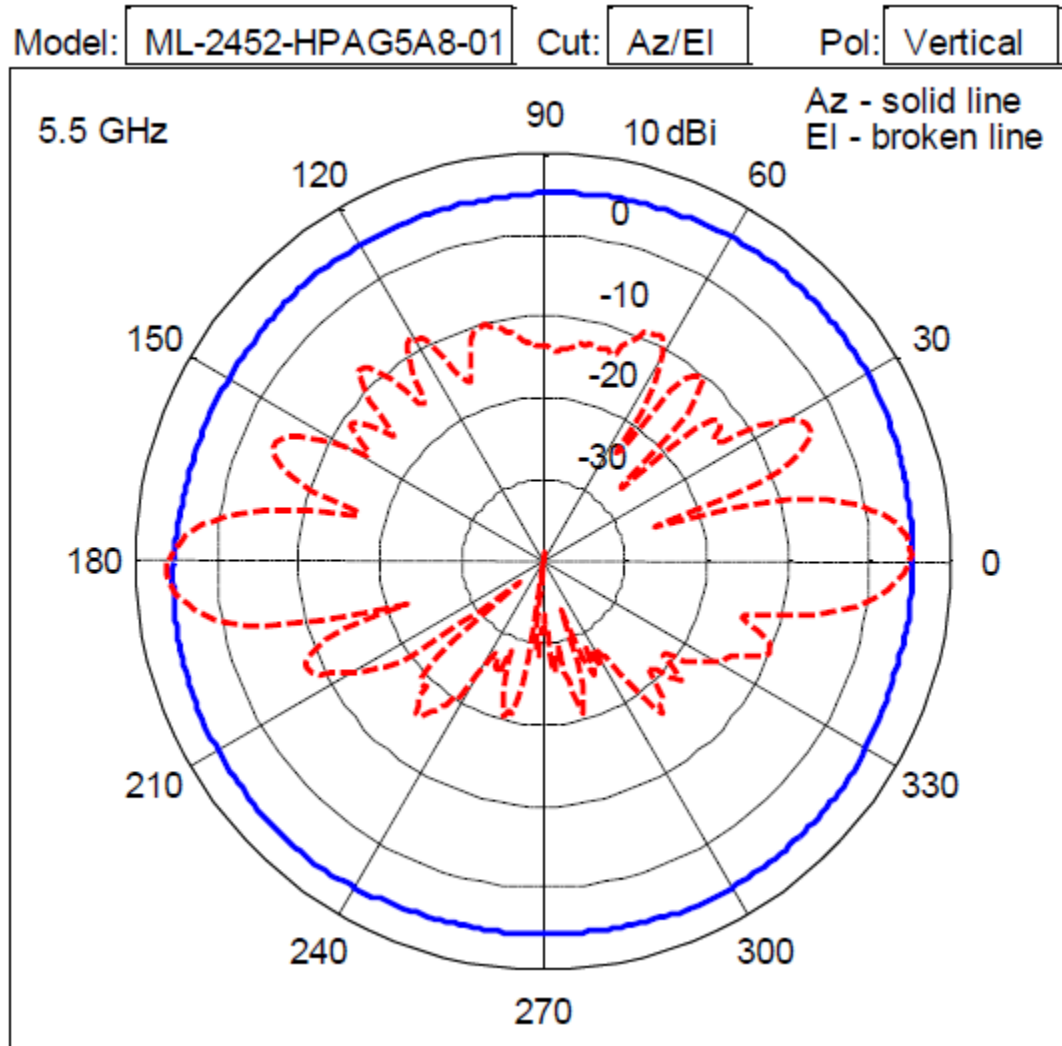


Figure 23: 2.45 GHz azimuth and elevation pattern

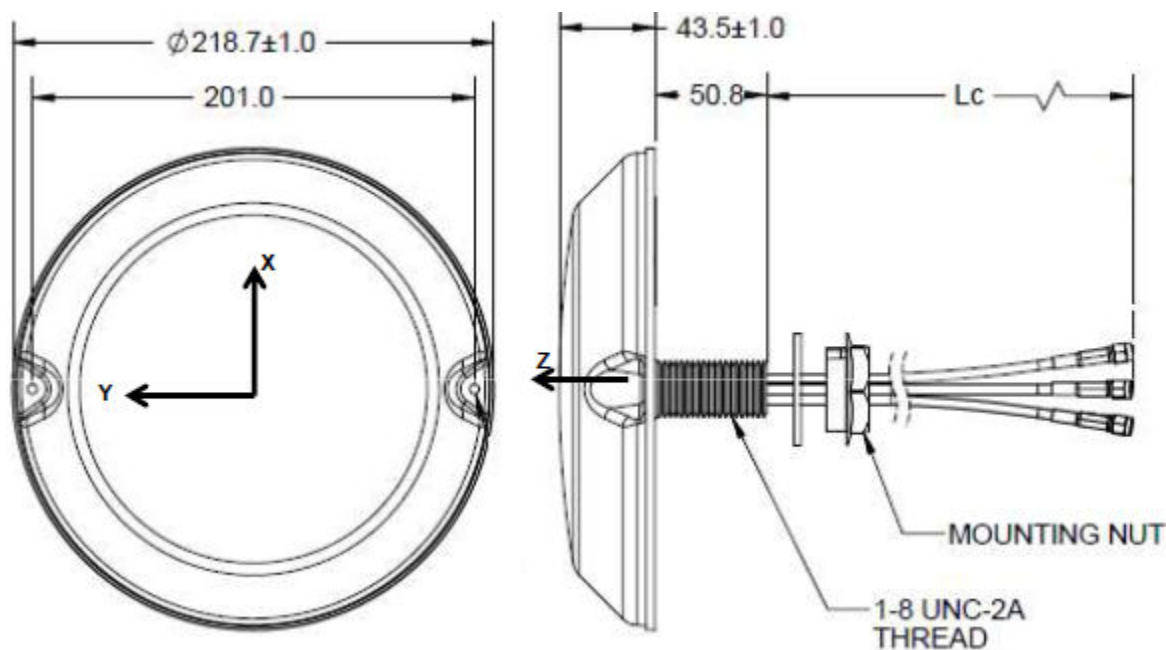


**Figure 24: 5.5 GHz azimuth and elevation pattern**

Related Topics

[Install the ML-2452-HPAG5A8-01 Antenna](#) on page 111

## ML-2452-PTA4M4-036 Antenna Specifications and Radiation Patterns



**Figure 25: ML-2452-PTA4M4-036 antenna**

**Table 24: ML-2452-PTA4M4-036 antenna technical specifications**

Parameter	Performance
Maximum power	5 watts
Polarization	Linear, omnidirectional
Nominal impedance	50 $\Omega$
VSWR	2:1
Radome material	Acrylic styrene acrylonitrile (ASA)
Cable	36-inches RG-58 plenum-rated cable
Mounting method	Ceiling mount

**Table 25: ML-2452-PTA4M4-036 antenna electrical specifications**

Part number	Frequency range	Typical gain	Peak gain	Azimuth beamwidth	Elevation beamwidth	Connector
	2.4 GHz - 2.5 GHz	4.0 dBi	5.0 dBi	Omnidirectionality	70°	RP-SMA plug

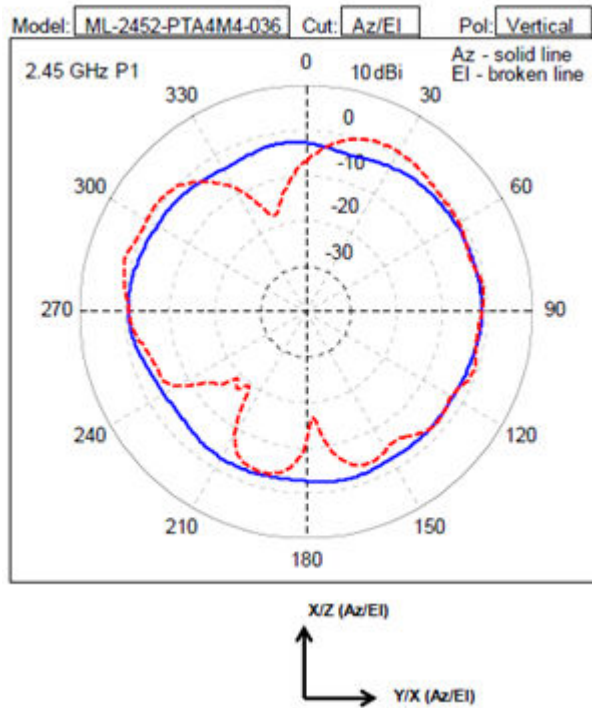
**Table 25: ML-2452-PTA4M4-036 antenna electrical specifications (continued)**

Part number	Frequency range	Typical gain	Peak gain	Azimuth beamwidth	Elevation beamwidth	Connector
ML-2452-PTA4M4-036	5.1 GHz – 5.9 GHz	5.7 dBi	6.6 dBi	Omnidirectivity	50°	

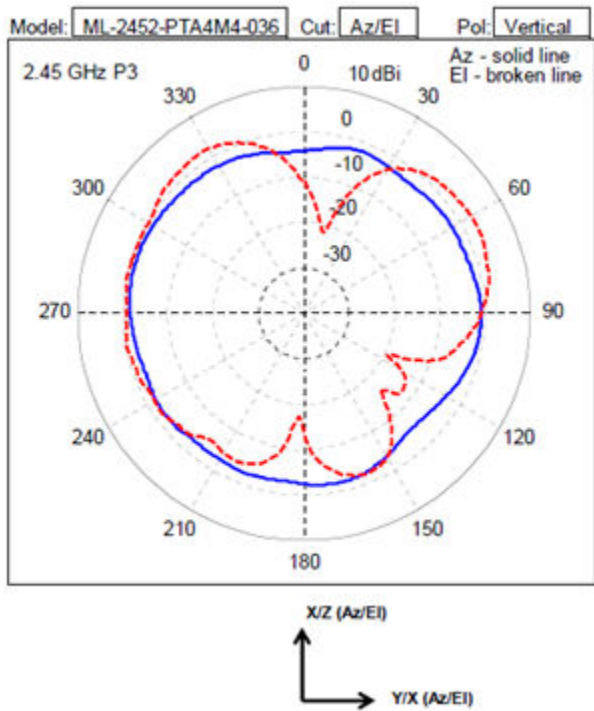
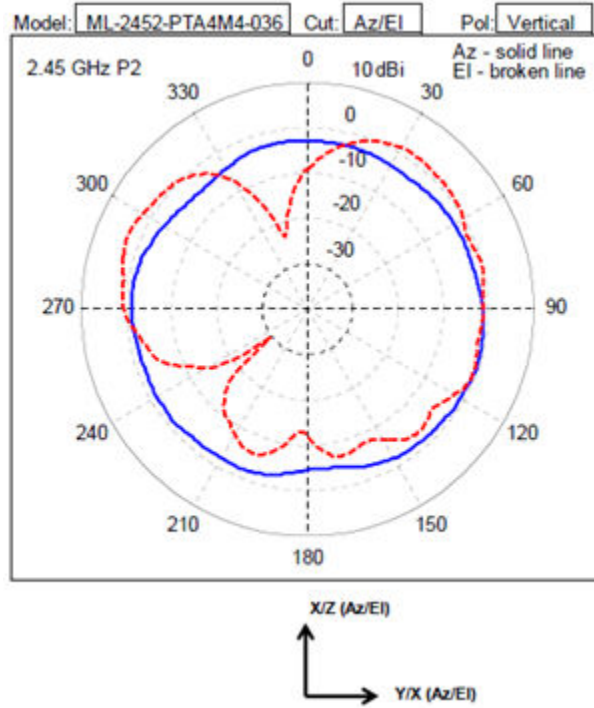
**Table 26: ML-2452-PTA4M4-036 antenna mechanical specifications**

Weight	Temperature
1.10 lb (0.50 kg)	Storage and operating temperature: -40°C to +70°C (-22°F to +158°F)

ML-2452-PTA4M4-036 antenna radiation patterns



**Figure 26: 2.4 GHz azimuth and elevation patterns**



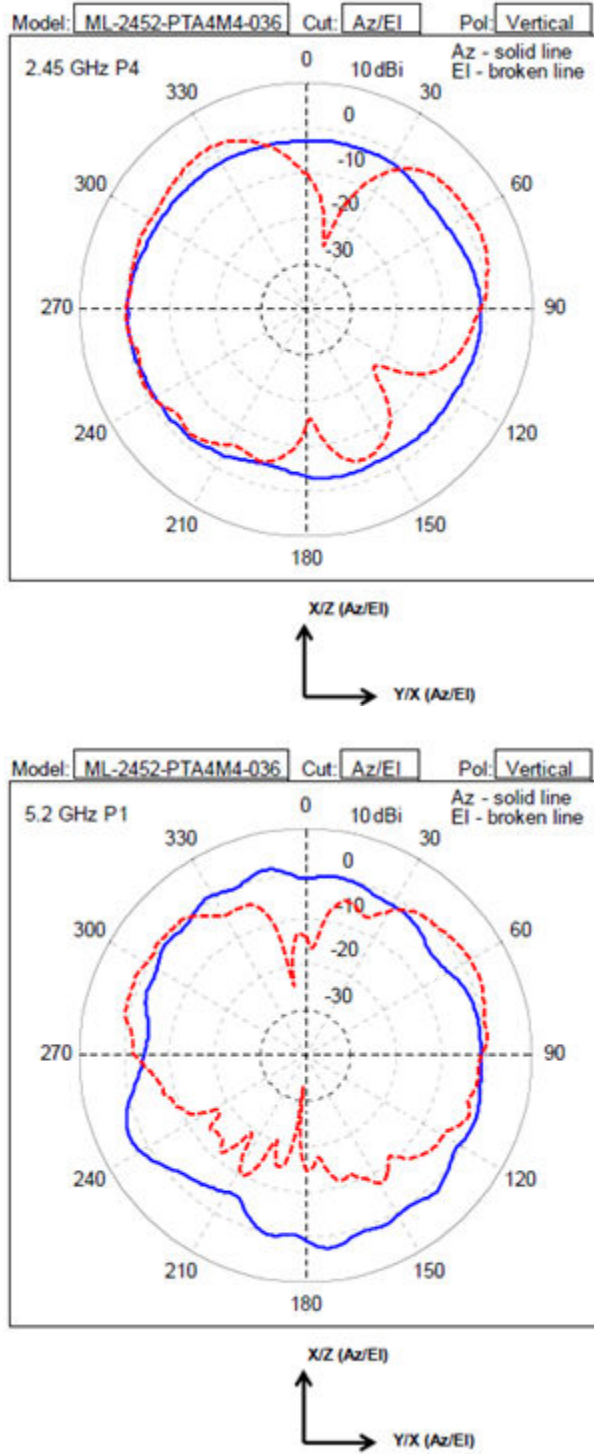
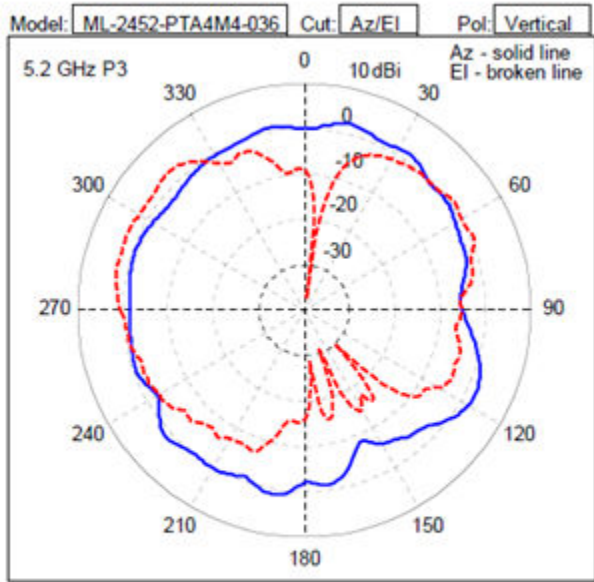
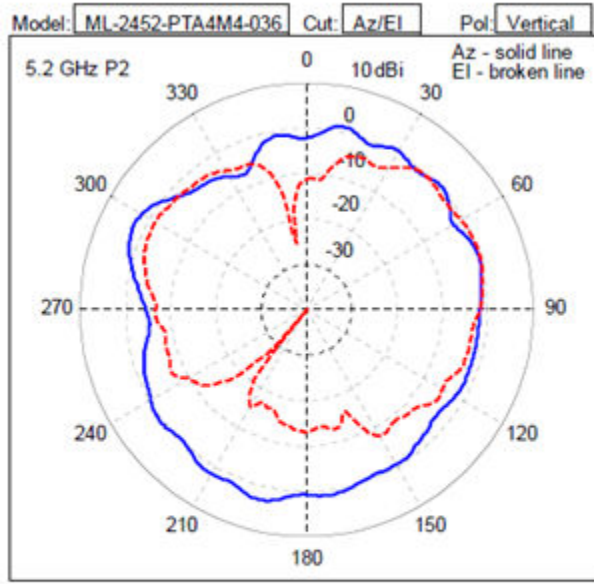
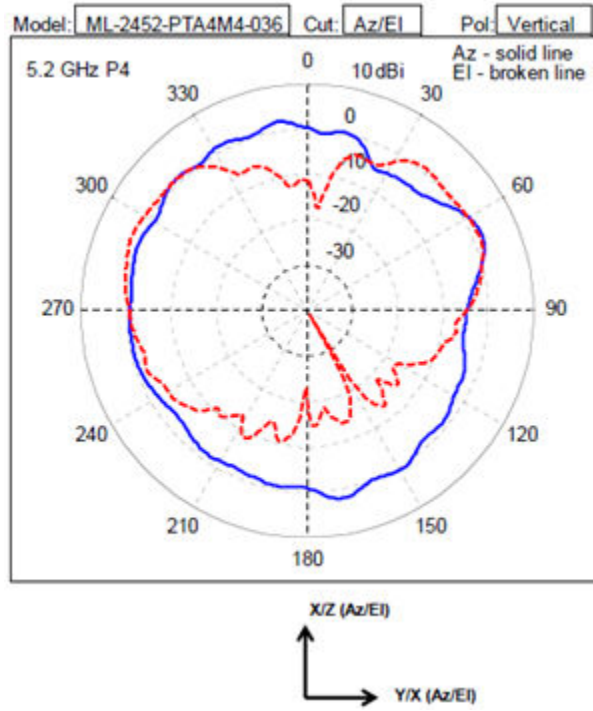


Figure 27: 5.2 GHz azimuth and elevation patterns



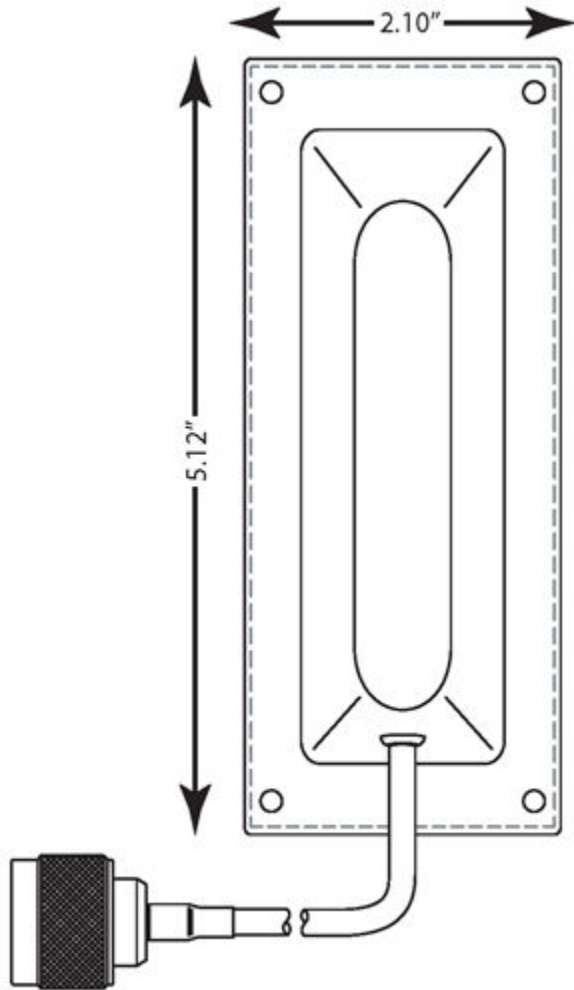


## Related Topics

[Install the ML-2452-PTA4M4-036 Antenna on page 114](#)



## ML-2452-PNA5-01R Antenna Specifications and Radiation Patterns



**Figure 28: ML-2452-PNA5-01R antenna**

**Table 27: ML-2452-PNA5-01R antenna technical specifications**

Parameter	Performance
Maximum power	5 watts
Polarization	Linear, vertical
Nominal impedance	50 $\Omega$
VSWR	2:1
Radome material	KYDEX® 100 thermoplastic

**Table 27: ML-2452-PNA5-01R antenna technical specifications (continued)**

Parameter	Performance
Cable	12-inches RG-58 plenum-rated cable
Mounting method	Wall mount Pole mount

**Table 28: ML-2452-PNA5-01R antenna electrical specifications**

Part number	Frequency range	Typical gain	Peak gain	Azimuth beamwidth	Elevation beamwidth	Connector
ML-2452-PNA5-01R	2.4-2.5 GHz	3.0 dBi	4.5 dBi	120°	60°	Standard N-plug connector
	4.9-5.9 GHz	3.5 dBi	5.0 dBi	120°	60°	

**Table 29: ML-2452-PNA5-01R antenna mechanical specifications**

Wind rating	Dimensions	Weight	Temperature
100 mph	131.06 mm × 54.86 mm × 35.05 mm	0.20 lb (0.09 kg)	Storage and operating temperature: -30°C to +70°C (-22°F to +158°F)

ML-2452-PNA5-01R antenna radiation patterns

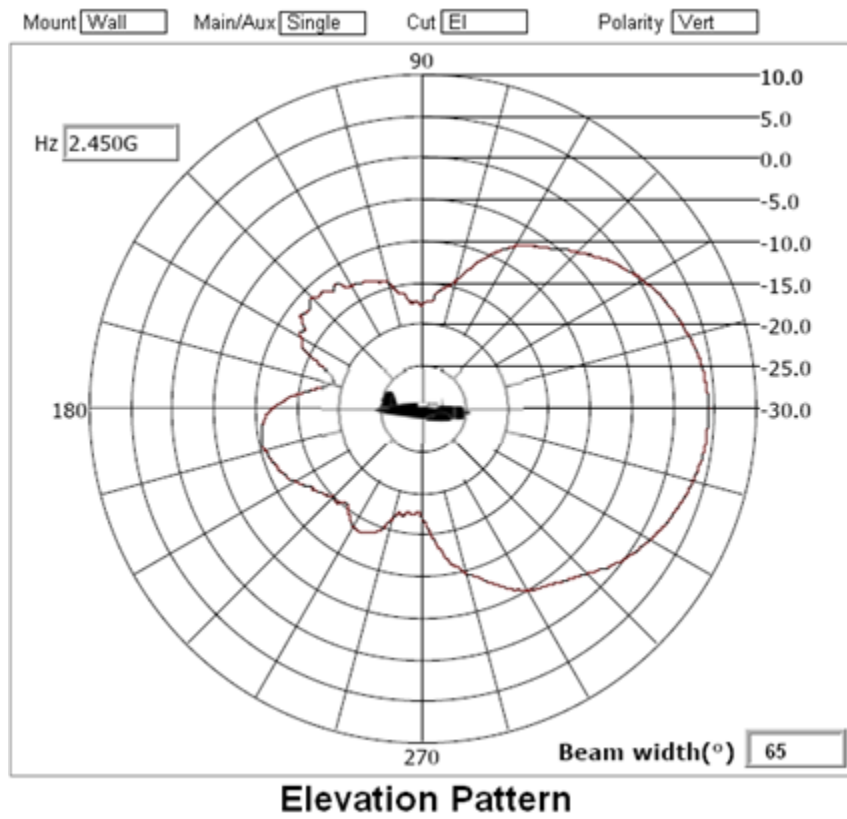
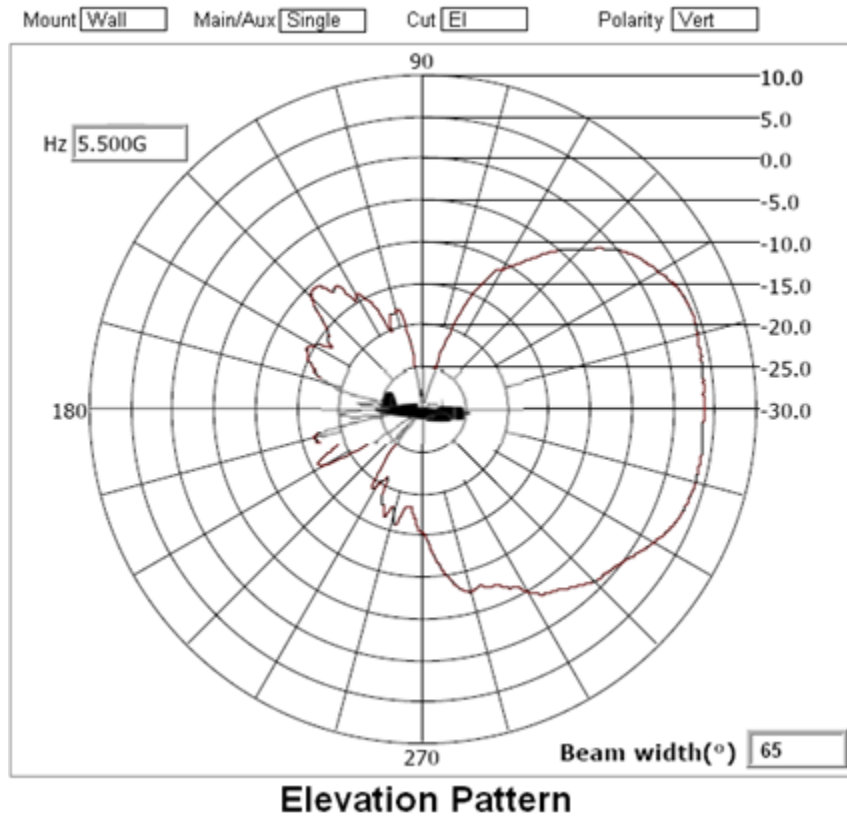


Figure 29: 2.4 GHz elevation pattern

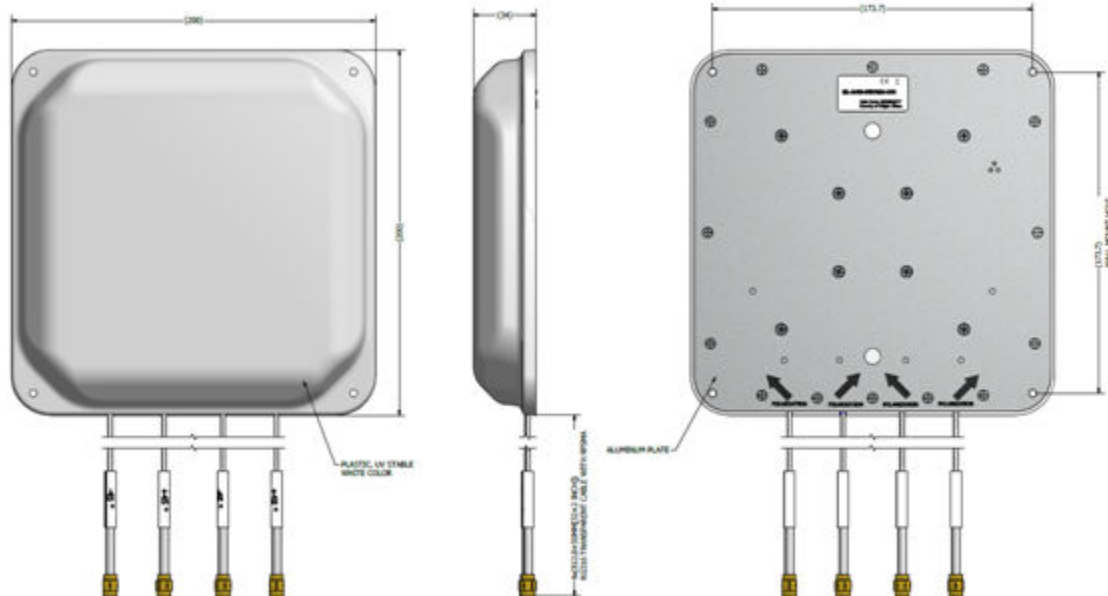


**Figure 30: 5.5 GHz elevation pattern**

Related Topics

[Install the ML-2452-PNA5-01R Antenna](#) on page 115

## ML-2452-SEC6M4-036 Antenna Specifications and Radiation Patterns



**Figure 31: ML-2452-SEC6M4-036 antenna**

**Table 30: ML-2452-SEC6M4-036 antenna technical specifications**

Parameter	Performance
Maximum power	20 watts
Polarization	Linear, vertical
VSWR	2
Radome material	UV stable plastic
Cable	32-inches RG316 plenum-rated transparent cable
Mounting method	Wall mount

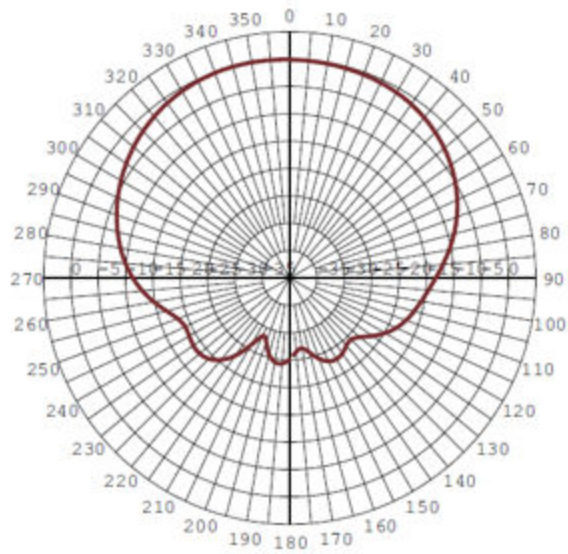
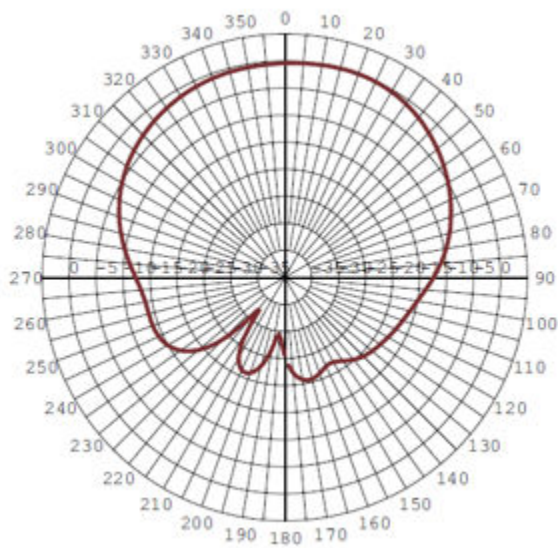
**Table 31: ML-2452-SEC6M4-036 antenna electrical specifications**

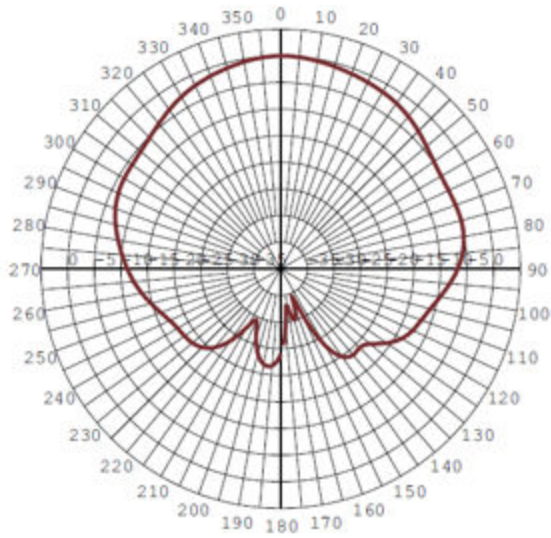
Part number	Frequency range	Azimuth beamwidth	Elevation beamwidth	Connector
ML-2452-SEC6M4-036	2.4 GHz - 2.5 GHz	100°	90°	RP-SMA plug
	5.1 GHz - 5.9 GHz	80°	65°	

**Table 32: ML-2452-SEC6M4-036 antenna mechanical specifications**

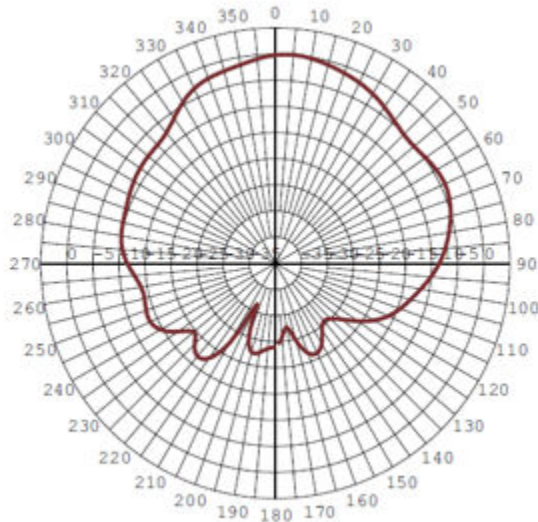
Weight	Temperature range
1.00 lb (0.45 kg)	Storage and operating temperature: -40°C to +70°C (-40°F to +158°F)

## ML-2452-SEC6M4-036 antenna radiation patterns

**Figure 32: 2.5 GHz azimuth pattern****Figure 33: 2.5 GHz elevation pattern**



**Figure 34: 5 GHz azimuth pattern**



**Figure 35: 5 GHz elevation pattern**

Related Topics

[Install the ML-2452-SEC6M4-036 Antenna](#) on page 122

## ML-2452-PNA7-01R Antenna Specifications and Radiation Patterns

**Table 33: ML-2452-PNA7-01R antenna technical specifications**

Parameter	Performance
Maximum power	2 watts
Polarization	Linear, vertical

**Table 33: ML-2452-PNA7-01R antenna technical specifications (continued)**

Parameter	Performance
Nominal impedance	50 $\Omega$
VSWR	2:1
Radome material	ASA
Cable	12-inches RG-58 plenum-rated cable
Mounting method	Wall or pole mount

**Table 34: ML-2452-PNA7-01R antenna electrical specifications**

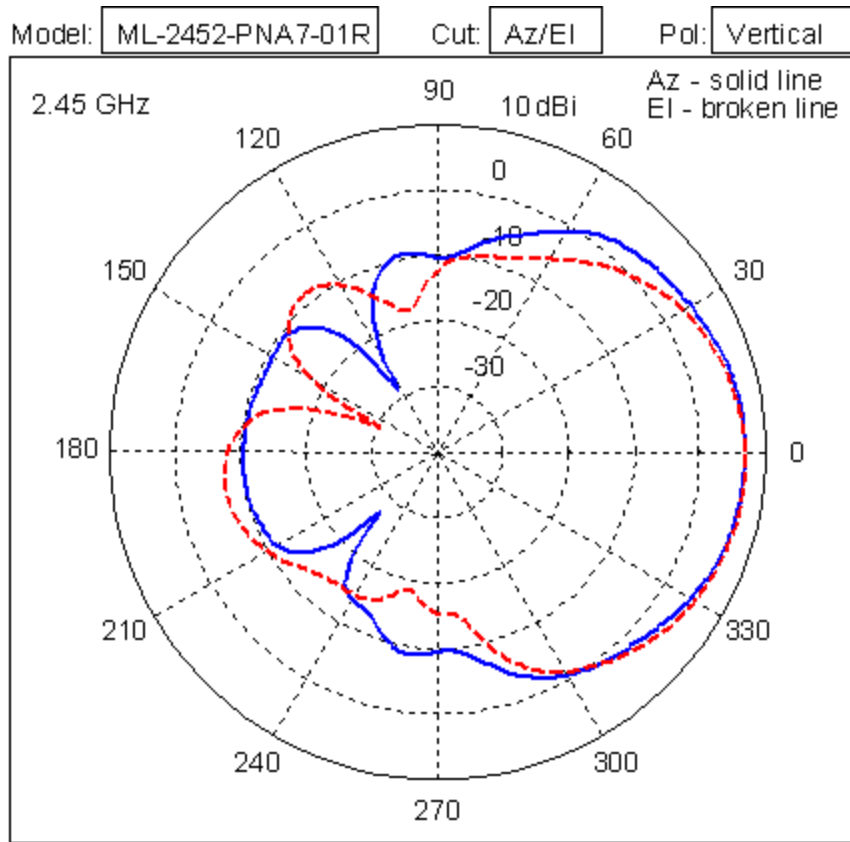
Part number	Frequency range	Typical gain	Peak gain	Azimuth beamwidth	Elevation beamwidth	Connector
ML-2452-PNA7-01R	2.4-2.5 GHz	7.3 dBi	7.0 dBi	68°	66°	Standard N-plug connector
	4.9-5.9 GHz	12.0 dBi	10.5 dBi	52°	60°	

**Table 35: ML-2452-PNA7-01R antenna mechanical specifications**

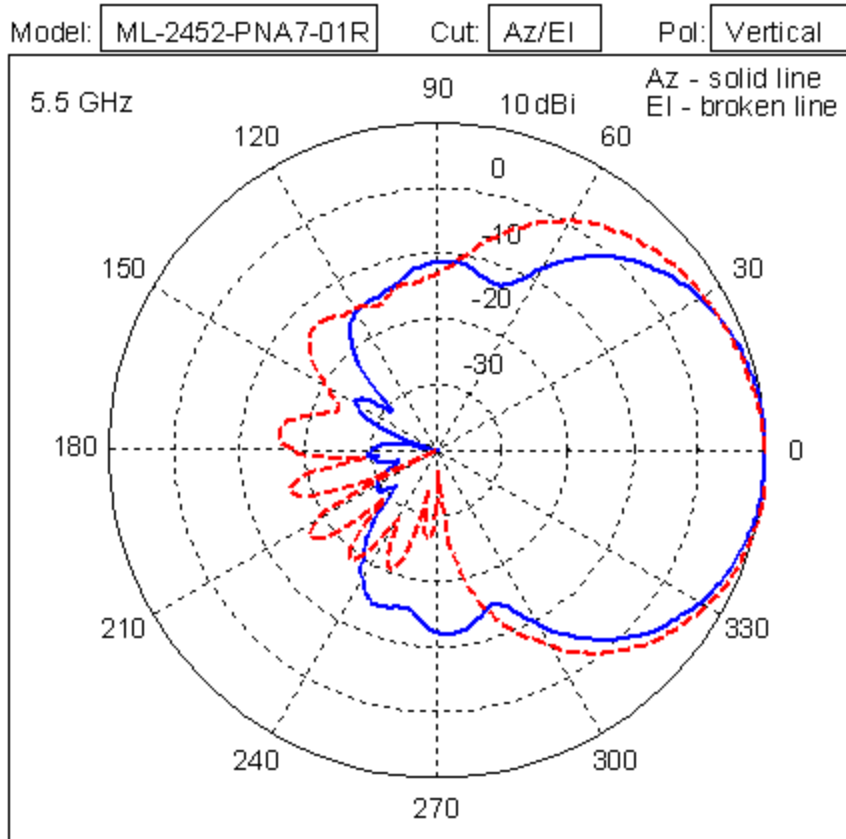
Wind rating	Dimensions	Weight	Temperature
100 mph	105.66 mm × 105.6 mm × 35.05 mm	0.50 lb (0.23 kg)	Storage temperature: -40°C to +85°C (-40°F to +185°F) Operating temperature: -30°C to +70°C (-22°F to +158°F)



### ML-2452-PNA7-01R antenna radiation patterns



**Figure 36: 2.4 GHz azimuth and elevation patterns**



**Figure 37: 5.5 GHz azimuth and elevation patterns**

Related Topics

[Install the ML-2452-PNA7-01R Antenna](#) on page 125

## AI-DQ04360S Antenna Specifications and Radiation Patterns

The AI-DQ04360S is a dual-band, 4-port omnidirectional antenna, used with 802.11ac MIMO applications. The antenna covers both 2.4-2.5 GHz and 5.1-5.9 GHz in one radome. The antenna has UL94 V-0 radome and PC board, and conforms to UL's high burn flame retardant rating.



**Figure 38: AI-DQ04360S antenna front view**

**Table 36: AI-DQ04360S antenna technical specifications**

Parameter	Performance
Maximum power	5 watts
Polarization	Linear, vertical
Nominal impedance	50 $\Omega$
VSWR	2:1
Radome material	UV protected plastic
Cable	Four, 36-inches RG-58/U plenum-rated cables
Mounting method	Wall or mast mount

**Table 37: AI-DQ04360S antenna electrical specifications**

Part number	Frequency range	Typical gain	Peak gain	Azimuth beamwidth	Elevation beamwidth	Connector
AI-DQ04360S	2.4-2.5 GHz	4.25 dBi	5.5 dBi	Omni-directional	60°	RP-SMA plug
	5.1-5.9 GHz	5 dBi	6 dBi		33°	

**Table 38: AI-DQ04360S antenna mechanical specifications**

Wind rating	Dimensions	Weight	Temperature range
25 mph	218 mm × 160 mm	3.20 lb (1.45 kg)	Storage temperature: -40°C to +85°C (-40°F to +185°F)

AI-DQ04360S antenna radiation patterns

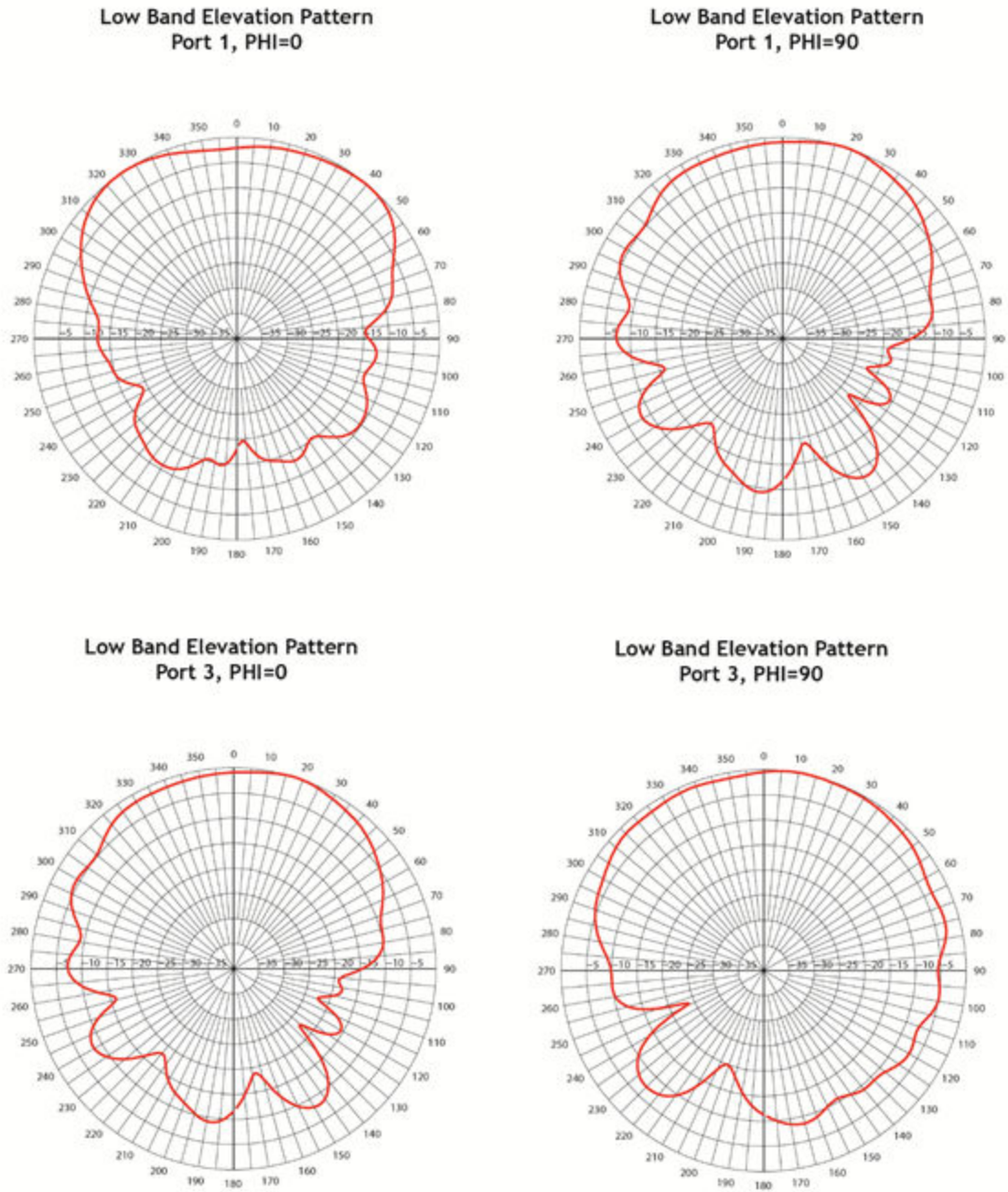
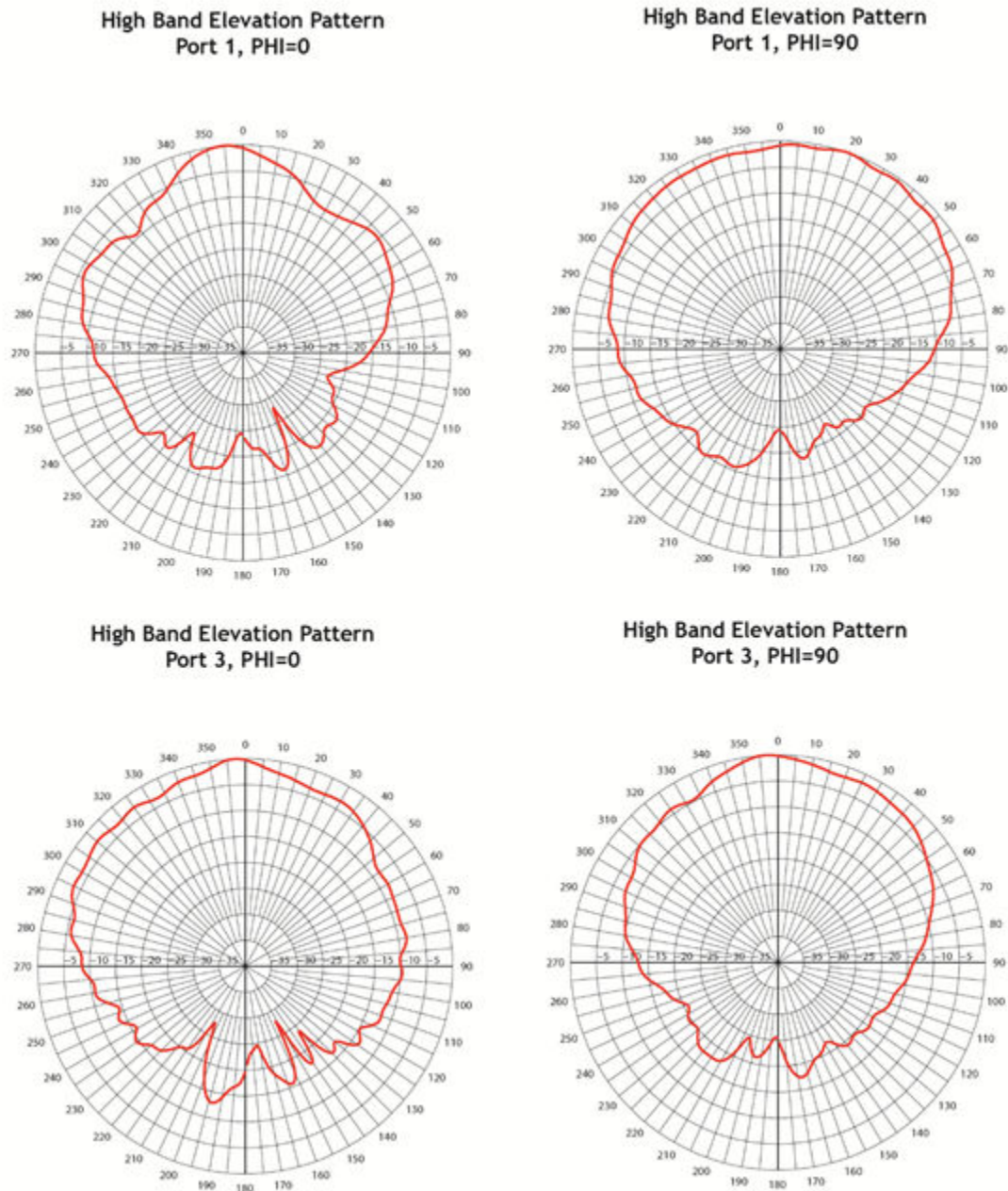


Figure 39: 2.4 GHz elevation patterns



**Figure 40: 5 GHz elevation patterns**

Related Topics

[Install the AI-DQ04360S Antenna](#) on page 129

## WS-AI-DQ05120 Antenna Specifications and Radiation Patterns

The WS-AI-DQ05120 is a 4-port sector antenna used for 802.11ac MIMO applications. The antenna covers both 2.4-2.5 GHz and 5.1-5.9 GHz in one radome. The four elements can also be used individually or in combination for use with legacy 802.11 access points. The antenna has UL94-HB radome and PC board, and conforms to UL's high burn flame retardant rating.



**Figure 41: WS-AI-DQ05120 antenna**

**Table 39: WS-AI-DQ05120 antenna technical specifications**

Item	Description
Maximum power	20 watts
Polarization	Dual-slat linear $\pm 45^\circ$
Nominal impedance	50 ohms
Voltage Standing Wave Ratio (VSWR)	1.5 typical 2.0 maximum
Front-to-back ratio	>20 dB
Radome material	UV protected plastic
Cable	Four 58 in. and 2 UL94 RG-316
Mounting method	Wall or pipe mount

**Table 40: WS-AI-DQ05120 antenna electrical specifications**

Part number	Frequency range	Typical gain	Peak gain	Azimuth beamwidth	Elevation beamwidth	Connector
	2.4 GHz - 2.5 GHz	5.0 dBi	5.5 dBi	100°	90°	RP-SMA plug

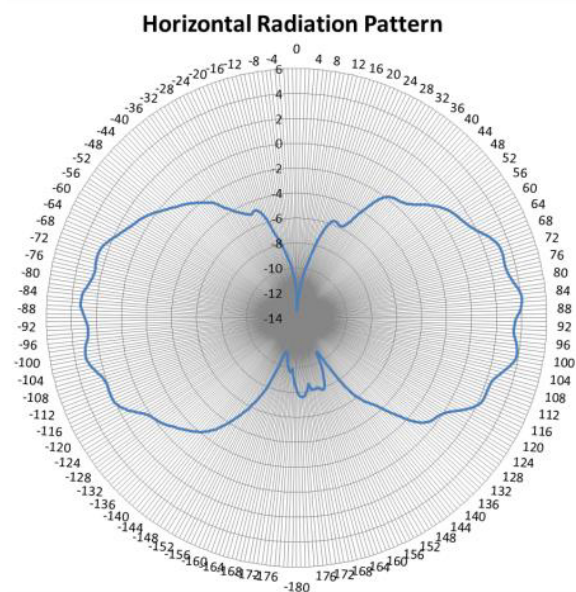
**Table 40: WS-AI-DQ05120 antenna electrical specifications (continued)**

Part number	Frequency range	Typical gain	Peak gain	Azimuth beamwidth	Elevation beamwidth	Connector
WS-AI-DQ05120 (30702)	5.1 GHz – 5.9 GHz	4.5 dBi	5.5 dBi	80°	65°	

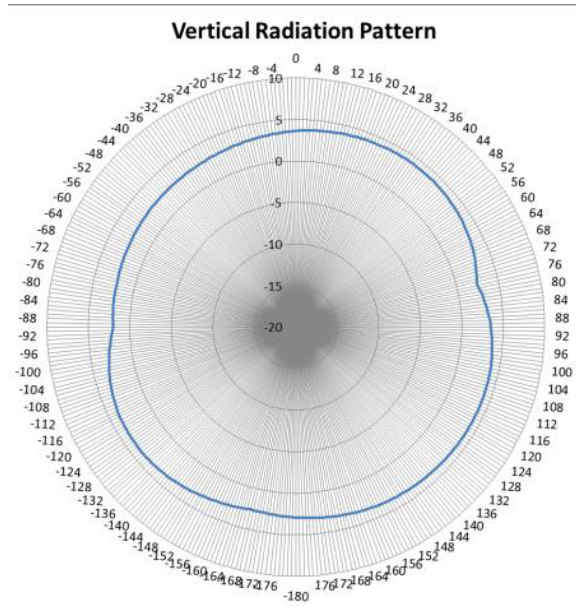
**Table 41: WS-AI-DQ05120 antenna mechanical specifications**

Part number	Dimensions	Weight	Temperature range
WS-AI-DQ05120 (30702)	200 mm × 200 mm × 34 mm	1.00 lb (0.45 kg)	Storage temperature: -40°C to +70°C (-40°F to +158°F)

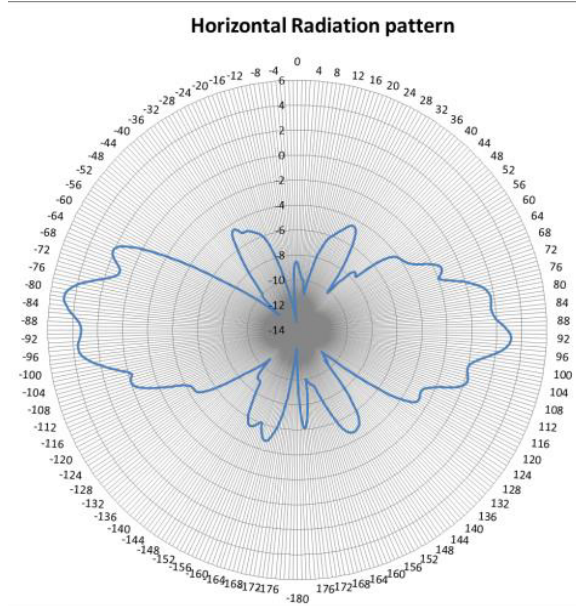
WS-AI-DQ05120 antenna radiation patterns



**Figure 42: 2.4 GHz azimuth pattern**

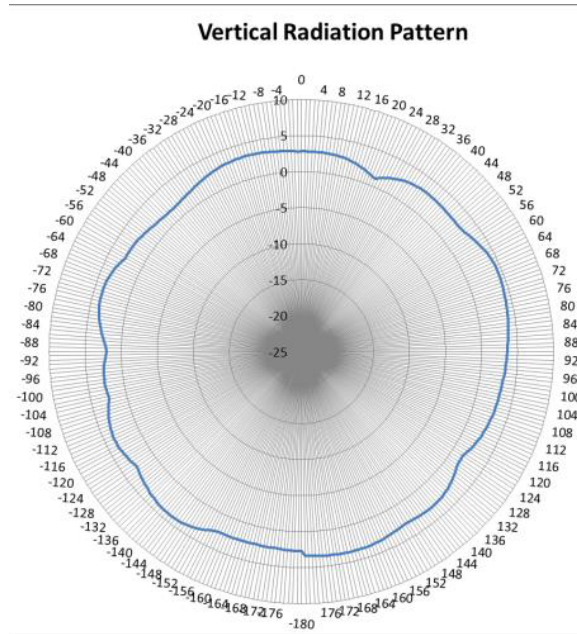


**Figure 43: 2.4 GHz elevation pattern**



**Figure 44: 5 GHz azimuth pattern**





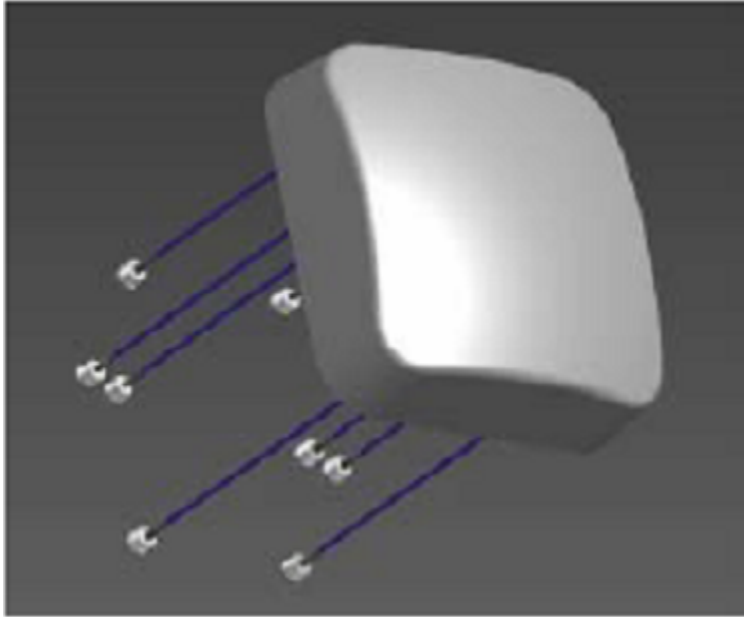
**Figure 45: 5 GHz elevation pattern**

#### Related Topics

[Install the WS-AI-DQ05120, WS-AI-DE07025, or WS-AI-DE10055 Antenna](#) on page 137

## WS-AI-DE07025 Antenna Specifications and Radiation Patterns

The WS-AI-DE07025 antenna is an 8-port sector antenna used for 802.11ac MIMO applications. The antenna covers both 2.4–2.5 GHz and 5.1–5.9 GHz in one radome. The elements can be used individually or in combination for use with legacy 802.11 access points. The UL-listed radome and PC board materials conform to UL's high burn flame-retardant rating.



**Figure 46: WS-AI-DE07025 antenna**

**Table 42: WS-AI-DE07025 antenna technical specifications**

Item	Description
Maximum power	25 watts
Polarization	Dual linear
Nominal impedance	50 $\Omega$
VSWR	<2.25:1
Front-to-back-ratio	>22 dB at 2.4 GHz >25 dB at 5 GHz
Front-to-side-ratio	17 dB at 2.4 GHz 15 dB at 5 GHz
Radome material	White, UL 94-HB plastic

**Table 42: WS-AI-DE07025 antenna technical specifications (continued)**

Item	Description
Cable	Eight 58 in. ± 2RG-58PLW plenum
Mounting method	Wall or pipe mount

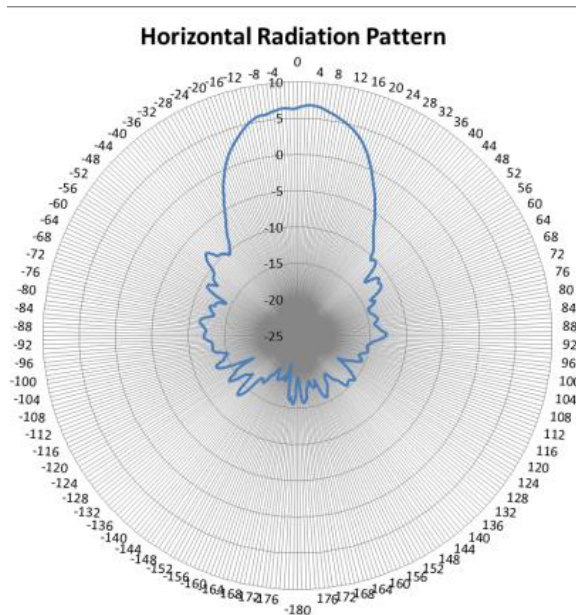
**Table 43: WS-AI-DE07025 antenna electrical specifications**

Part number	Frequency range	Typical gain	Peak gain	Azimuth beamwidth	Elevation beamwidth	Connector
30705	2.4 GHz - 2.5 GHz	6.5 dBi	7.5 dBi	31°	43°	RP-SMA male
	5.1 GHz - 5.9 GHz	5.5 dBi	6.5 dBi	29°	37°	

**Table 44: WS-AI-DE07025 antenna mechanical specifications**

Dimensions	Weight	Temperature range
305.0 mm × 305.0 mm × 110.5 mm	5.00 lbs (2.27 kg)	Storage temperature: -30°C to +80°C (-22°F to +176°F)

WS-AI-DE07025 antenna radiation patterns



**Figure 47: 2.4 GHz azimuth pattern**

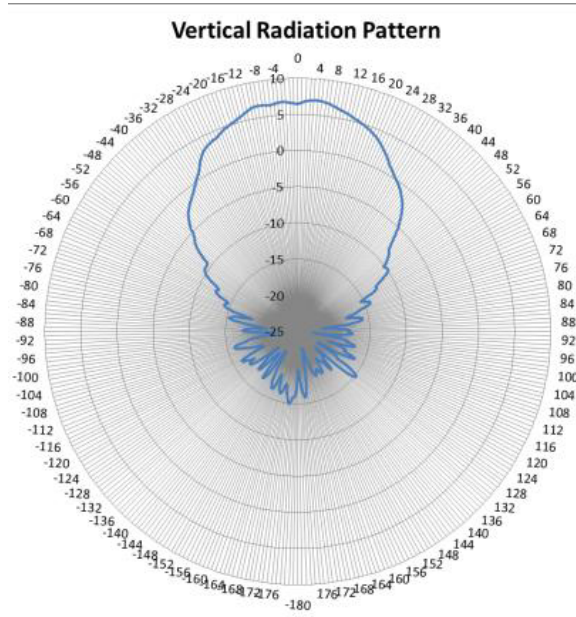


Figure 48: 2.4 GHz elevation pattern

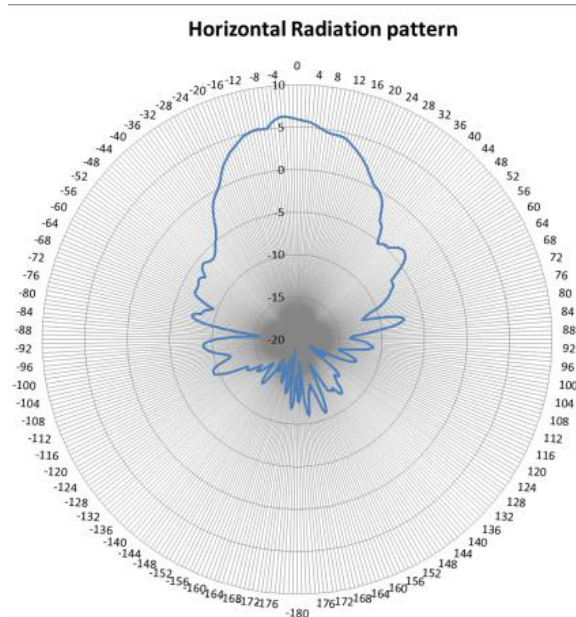
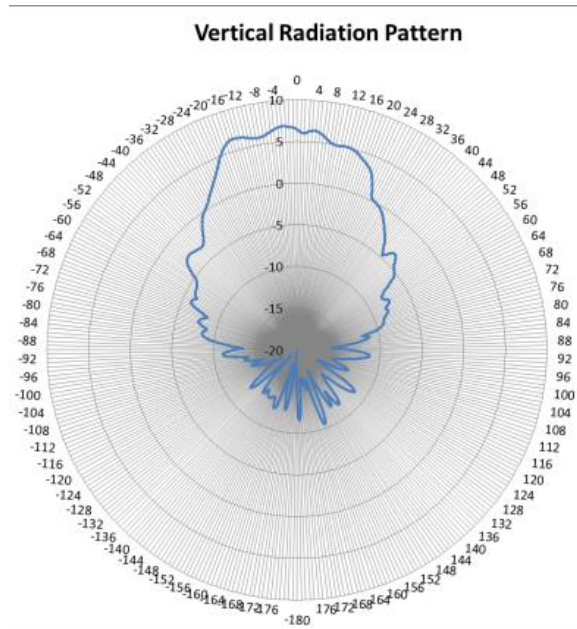


Figure 49: 5 GHz azimuth pattern



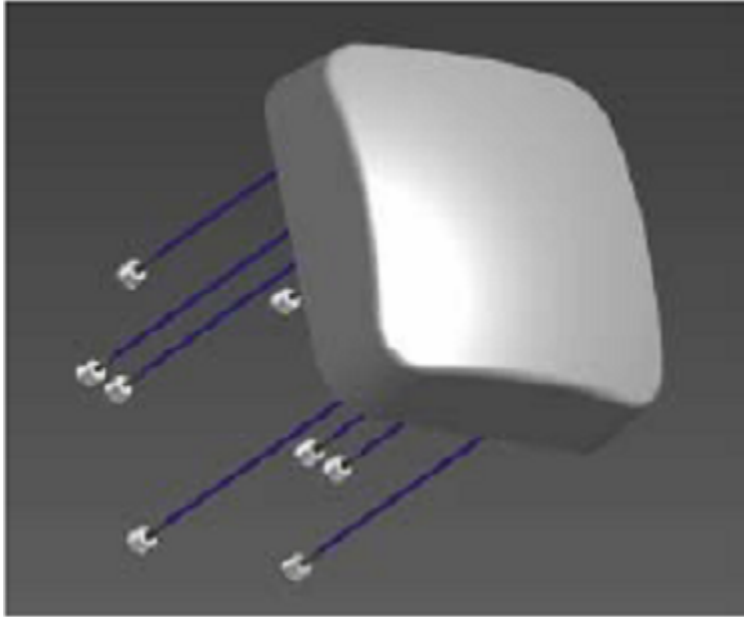
**Figure 50: 5 GHz elevation pattern**

Related Topics

[Install the WS-AI-DQ05120, WS-AI-DE07025, or WS-AI-DE10055 Antenna](#) on page 137

## WS-AI-DE10055 Antenna Specifications and Radiation Patterns

This dual-band 8-port sector antenna can be used for 802.11ac MIMO applications. The antenna covers both 2.4–2.5 GHz and 5.1–5.9 GHz in one radome. The radome can be used individually or in combination for use with legacy 802.11 access points.



**Figure 51: WS-AI-DE10055 antenna**

**Table 45: WS-AI-DE10055 antenna technical specifications**

Item	Description
Maximum power	25 watts
Polarization	Dual linear
Nominal impedance	50 $\Omega$
VSWR	<2.25:1
Front-to-back ratio	>21 dB at 2.4 GHz >14 dB at 5 GHz
Front-to-side ratio	15 dB at 2.4 GHz 14 dB at 5 GHz
Radome material	White, UL 94-HB plastic

**Table 45: WS-AI-DE10055 antenna technical specifications (continued)**

Item	Description
Cable	Eight 58 in. ±2 RG-58PLW plenum
Mounting method	Wall or pipe mount

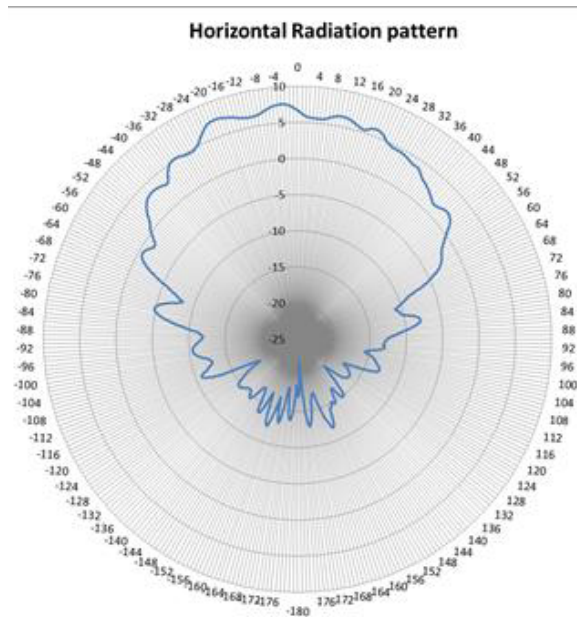
**Table 46: WS-AI-DE10055 antenna electrical specifications**

Part number	Frequency range	Typical gain	Peak gain	Azimuth beamwidth	Elevation beamwidth	Connector
30707	2.4 GHz - 2.5 GHz	10.0 dBi	10.5 dBi	51°	44°	RP-SMA male
	5.1 GHz - 5.9 GHz	6.0 dBi	7.5 dBi	53°	43°	

**Table 47: WS-AI-DE10055 antenna mechanical specifications**

Dimensions	Weight	Temperature range
305.0 mm × 305.0 mm × 110.5 mm	5.00 lbs (2.30 kg)	Storage temperature: -30°C to +80°C (-22°F to +176°F)

WS-AI-DE10055 antenna radiation patterns



**Figure 52: 2.4 GHz azimuth pattern**

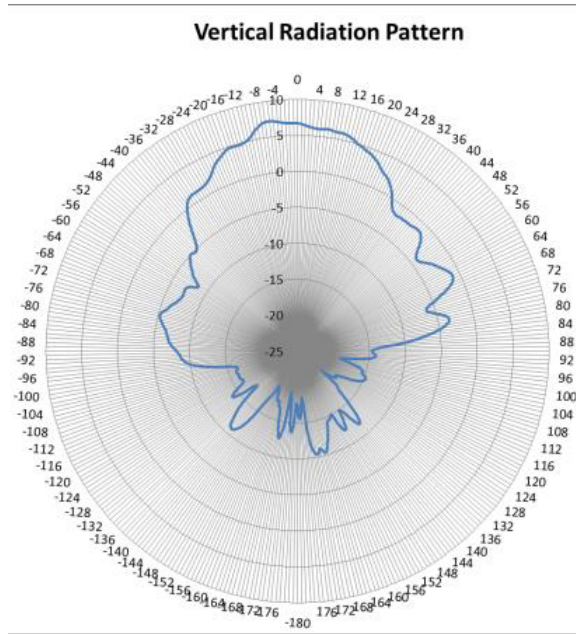


Figure 53: 2.4 GHz elevation pattern

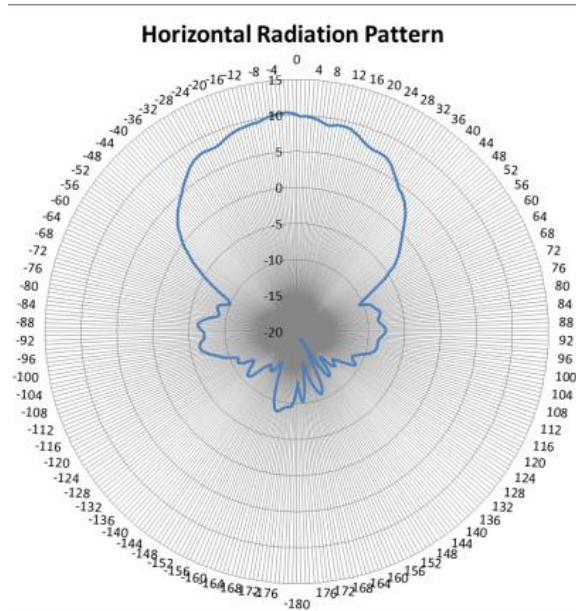
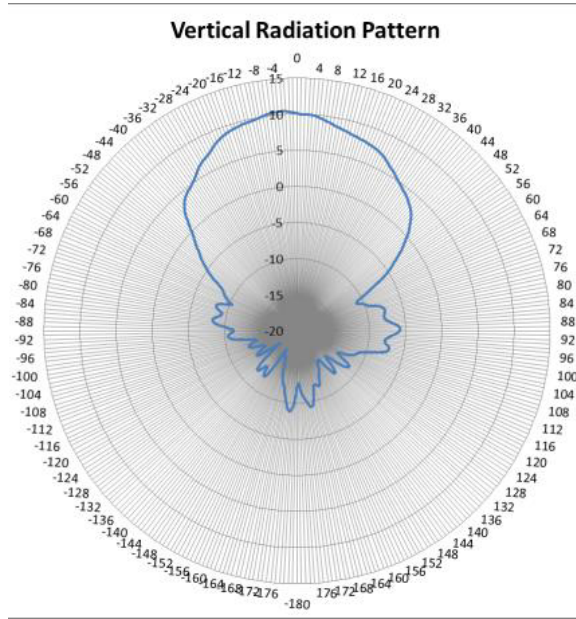


Figure 54: 5 GHz azimuth pattern





**Figure 55: 5 GHz elevation pattern**

Related Topics

[Install the WS-AI-DQ05120, WS-AI-DE07025, or WS-AI-DE10055 Antenna](#) on page 137

## WS-AO-DQ04360N Antenna Specifications and Radiation Patterns

The WS-AO-DQ04360N (30724) dual-band, 4-port, omni-directional antenna can be used for 802.11ac MIMO applications. The antenna covers both 2.4–2.5 GHz and 5.1–5.9 GHz in one radome. The antenna can be mounted on a wall or mast, and mount attachments are included.



**Figure 56: WS-AO-DQ04360N antenna**

**Table 48: WS-AO-DQ04360N antenna technical specifications**

Item	Description
Maximum power	5 watts
Polarization	Linear and vertical
Nominal impedance	50 $\Omega$
VSWR	2:1
Radome material	UV protected plastic
Cable	Four, 36 in. RG-58/U plenum-rated
Mounting method	Wall or mast mount

**Table 49: WS-AO-DQ04360N antenna electrical specifications**

Part number	Frequency range	Typical gain	Peak gain	Azimuth beamwidth	Elevation beamwidth	Connector
30724	2.4 GHz - 2.5 GHz	4.25 dBi	5.50 dBi	Omnidirectional	60°	N male
	5.1 GHz - 5.9 GHz	5.00 dBi	6.00 dBi		33°	

**Table 50: WS-AO-DQ04360N antenna mechanical specifications**

Dimensions	Weight	Temperature range
218.44.0 mm × 160.02 mm	3.20 lbs (1.45 kg)	Storage temperature: -40°C to +85°C (-40°F to +185°F)

### WS-AO-DQ04360N antenna radiation patterns

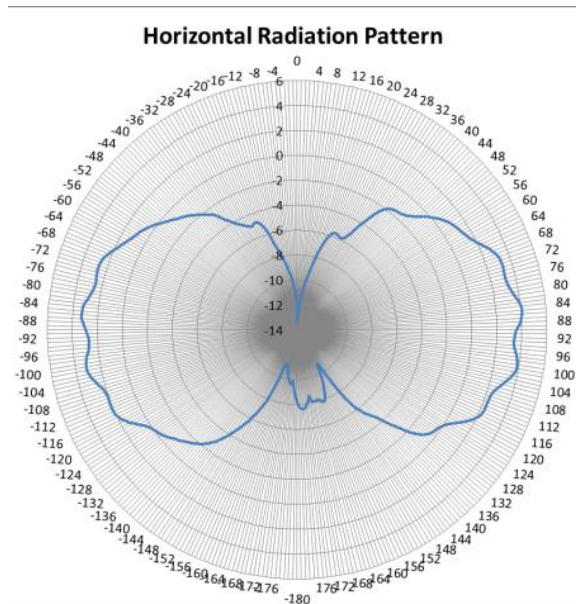


Figure 57: 2.4 GHz azimuth pattern

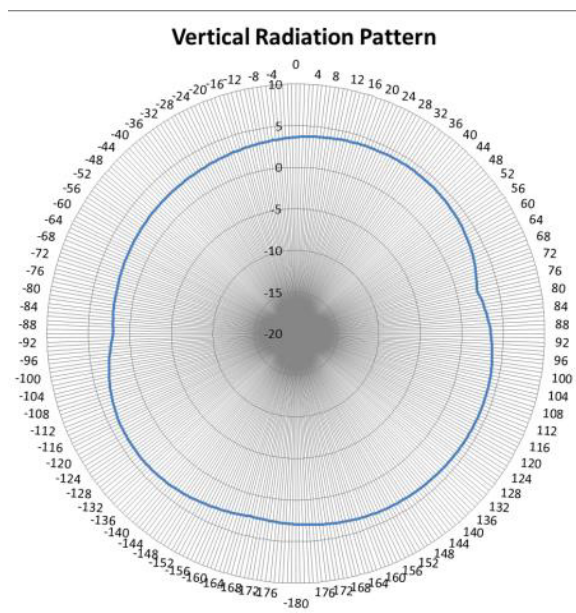
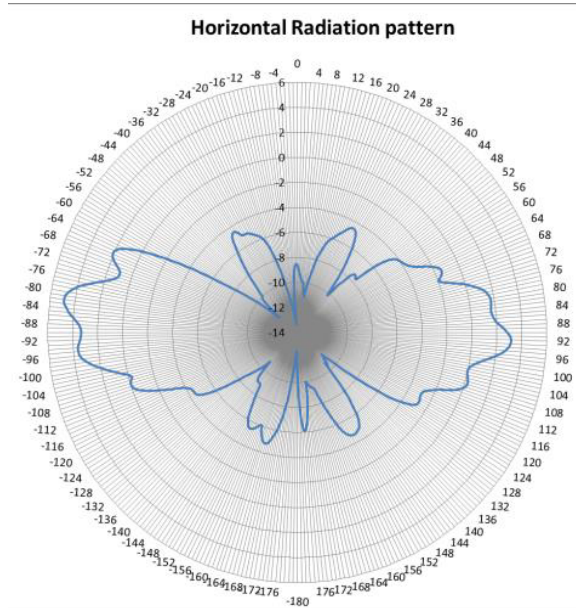
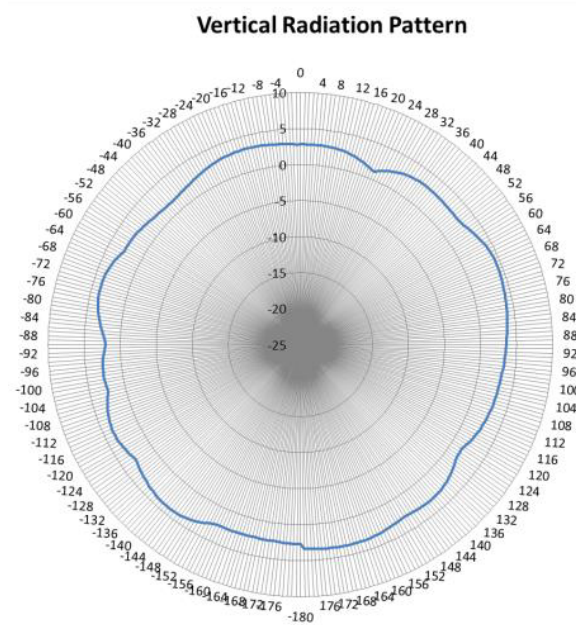


Figure 58: 2.4 GHz elevation pattern



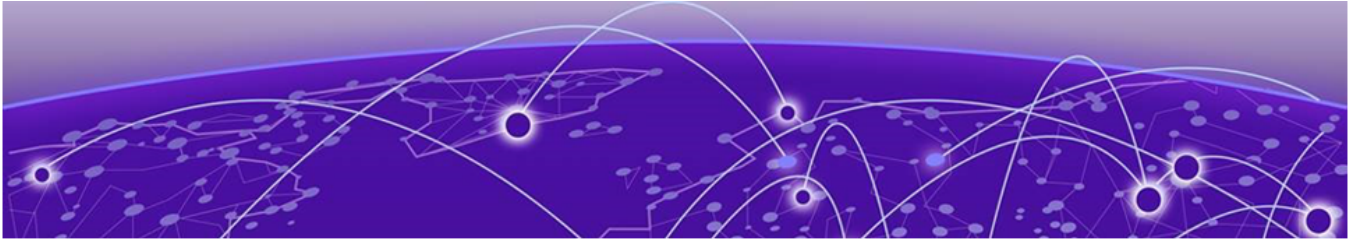
**Figure 59: 5 GHz azimuth pattern**



**Figure 60: 5 GHz elevation pattern**

Related Topics

[Install the WS-AO-DQ04360N Antenna](#) on page 143



# Internal Antenna Radiation Patterns

---

[AP505i Internal Antenna Radiation Patterns](#) on page 78

[AP510i Internal Antenna Radiation Patterns](#) on page 82

[AP560i Internal Antenna Radiation Patterns](#) on page 88

The following section lists the radiation patterns for the internal antennas used with ExtremeWireless indoor access points.

## AP505i Internal Antenna Radiation Patterns

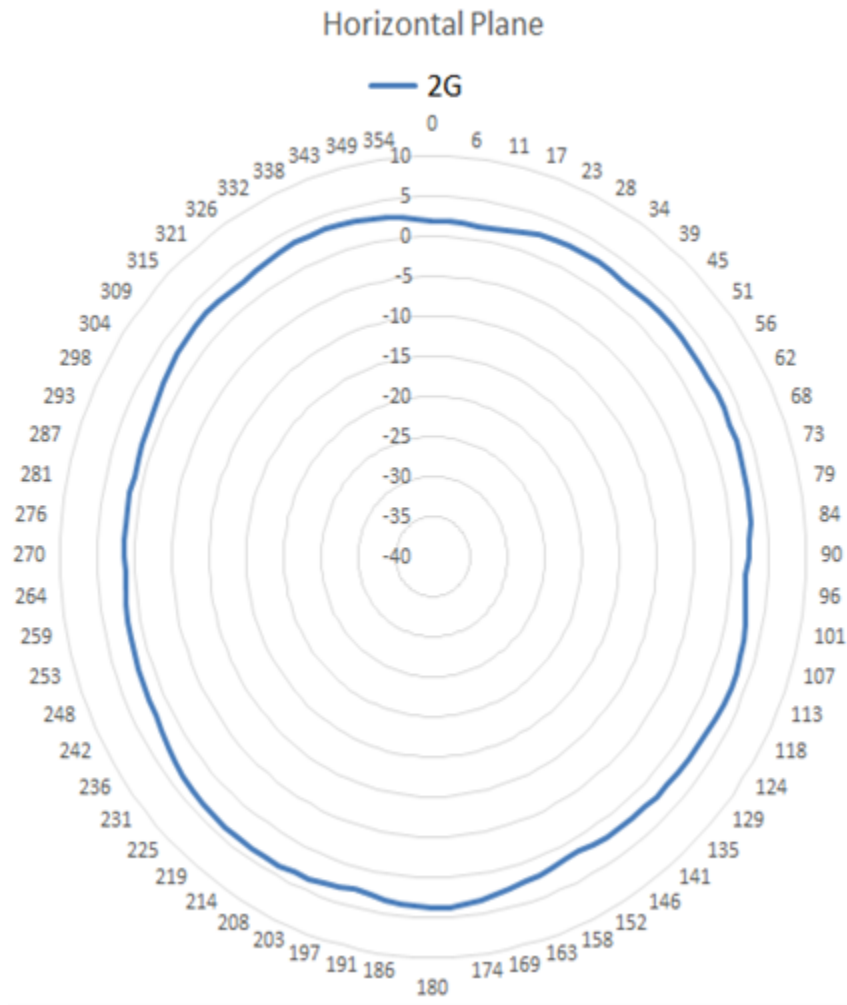


Figure 61: 2.4 GHz azimuth pattern

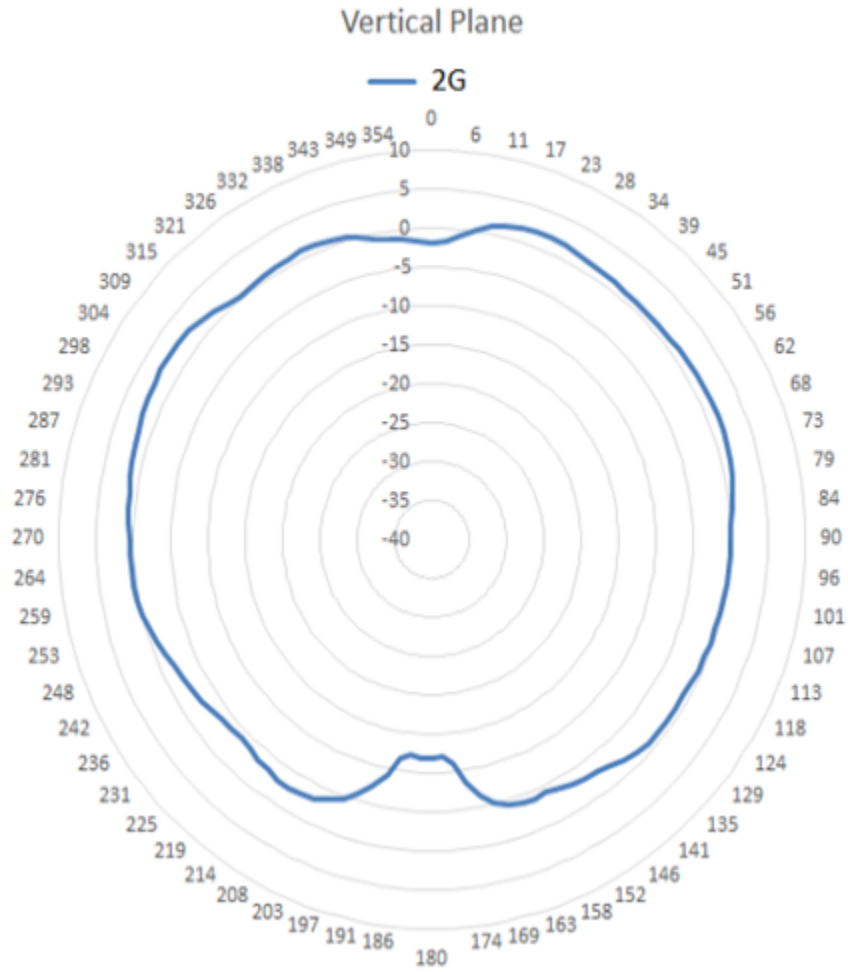


Figure 62: 2.4 GHz elevation pattern

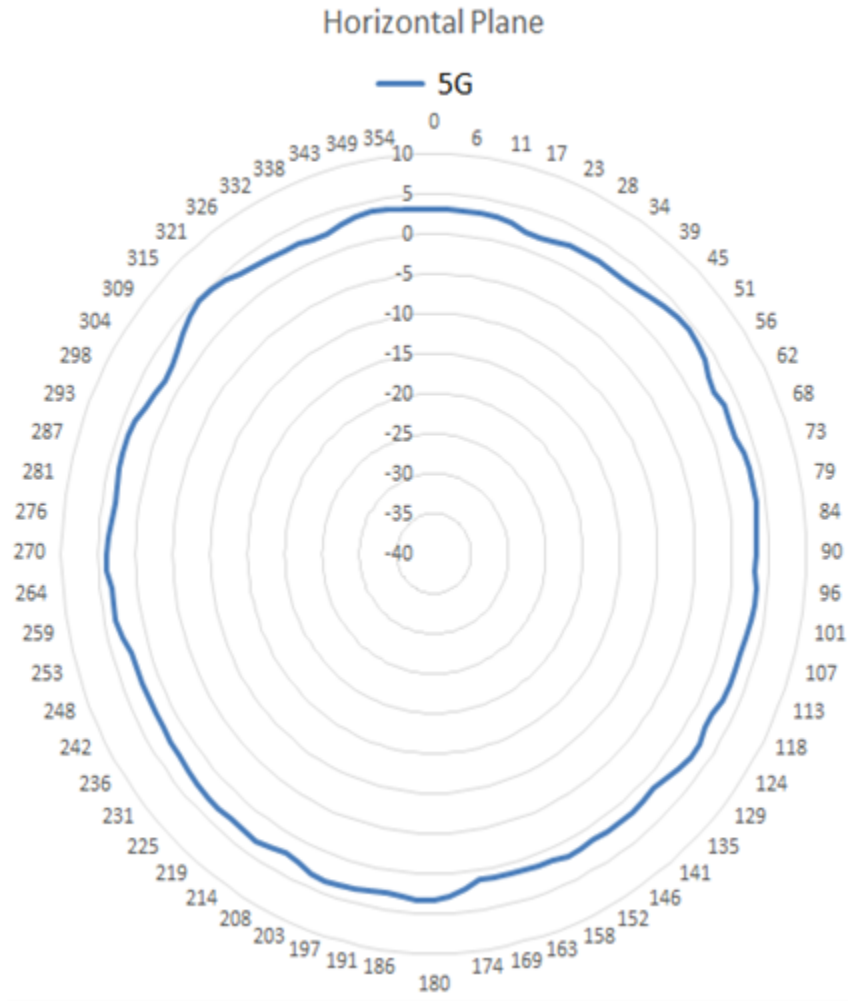


Figure 63: 5 GHz azimuth pattern



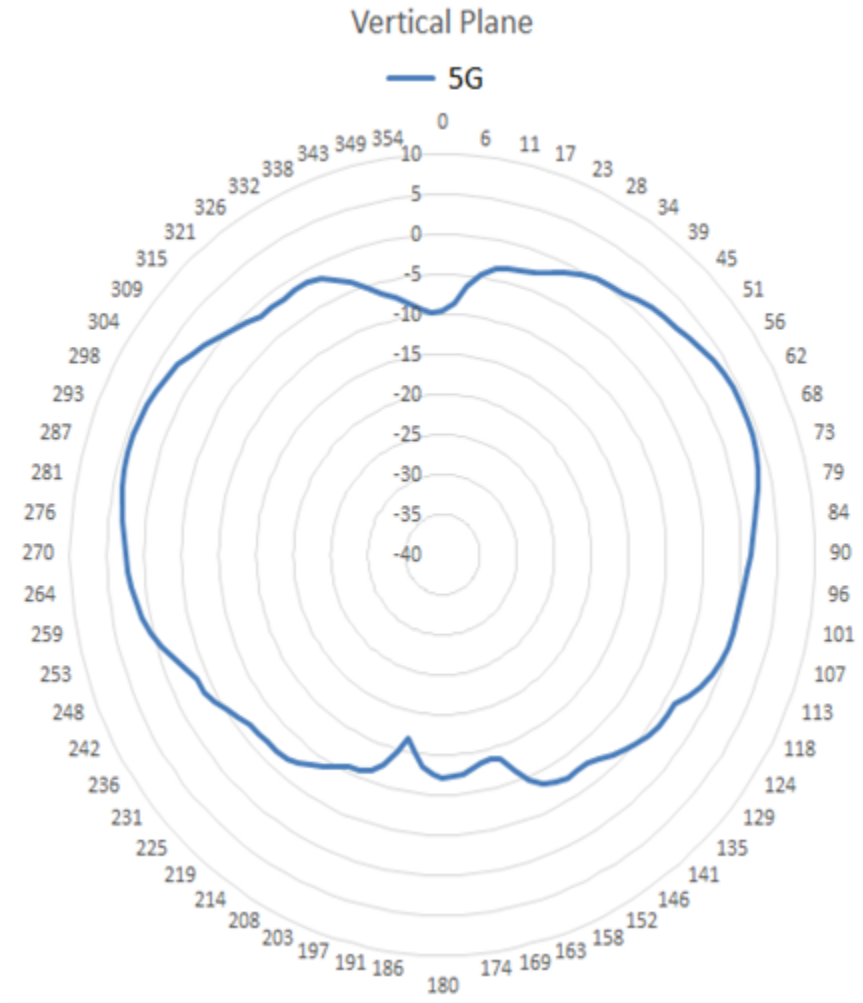


Figure 64: 5 GHz elevation pattern

## AP510i Internal Antenna Radiation Patterns

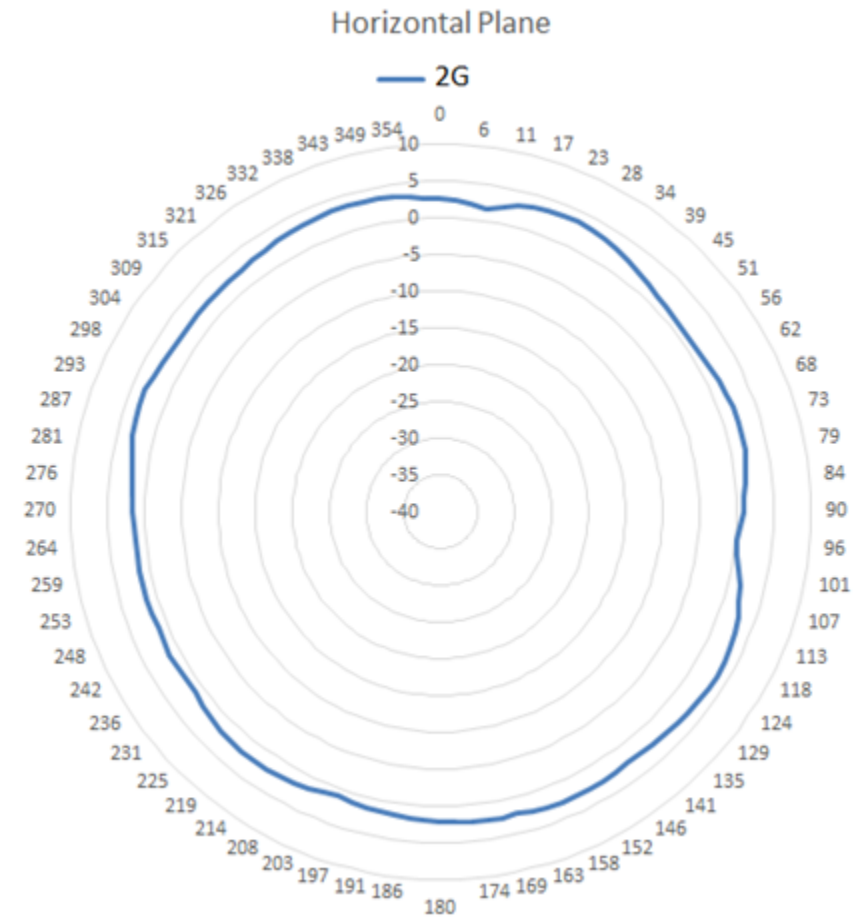
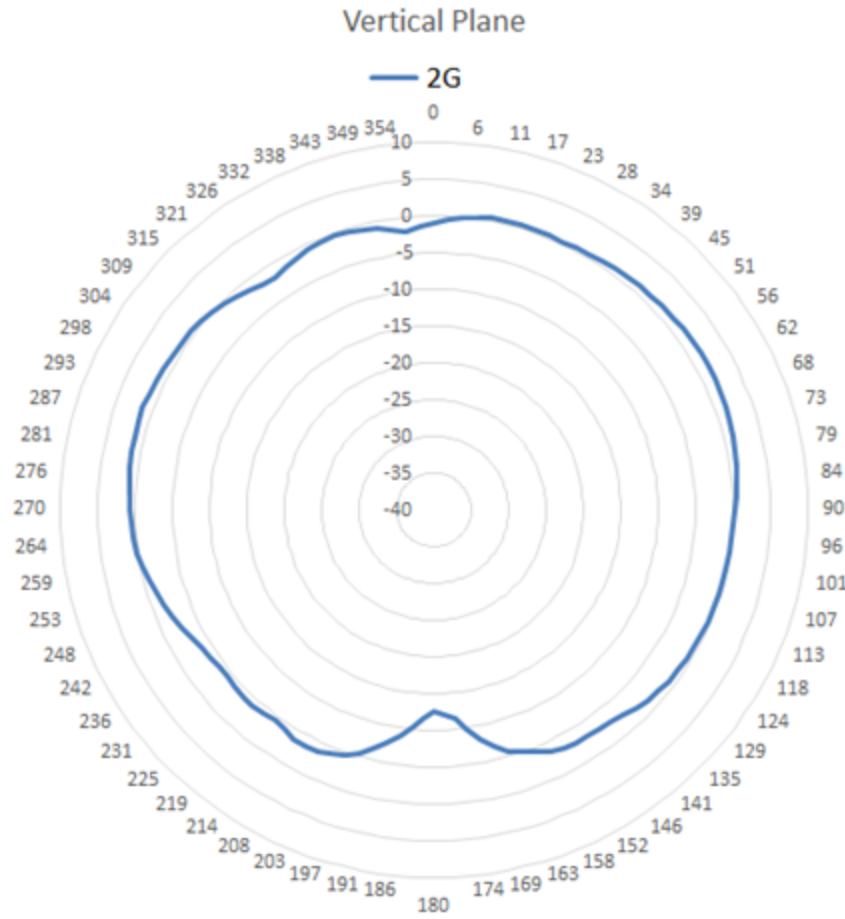


Figure 65: 2.4 GHz azimuth pattern



**Figure 66: 2.4 GHz elevation pattern**

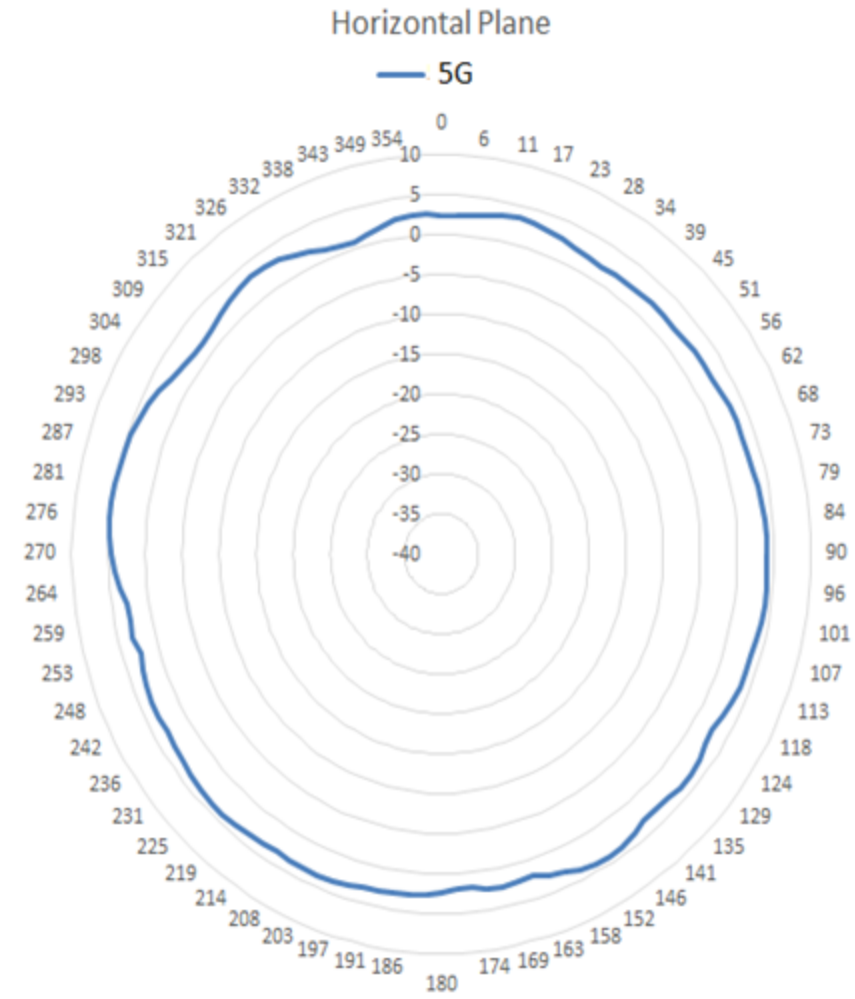


Figure 67: 5 GHz radio 1 azimuth pattern

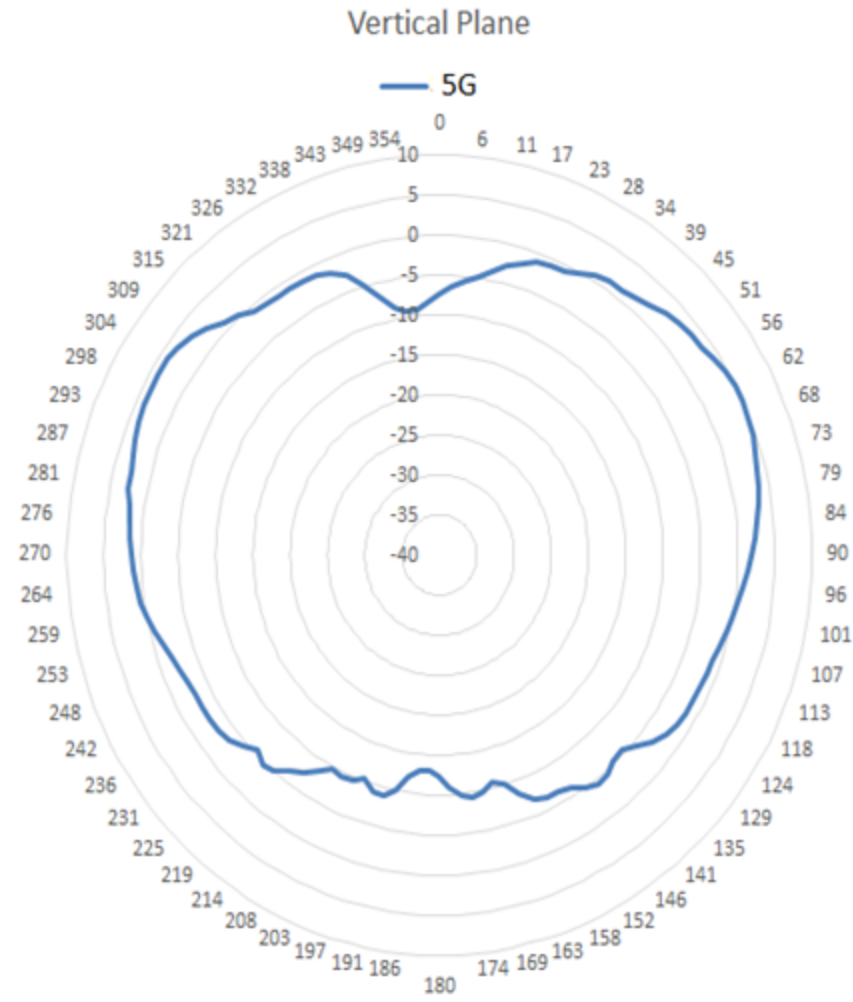


Figure 68: 5 GHz radio 1 elevation pattern

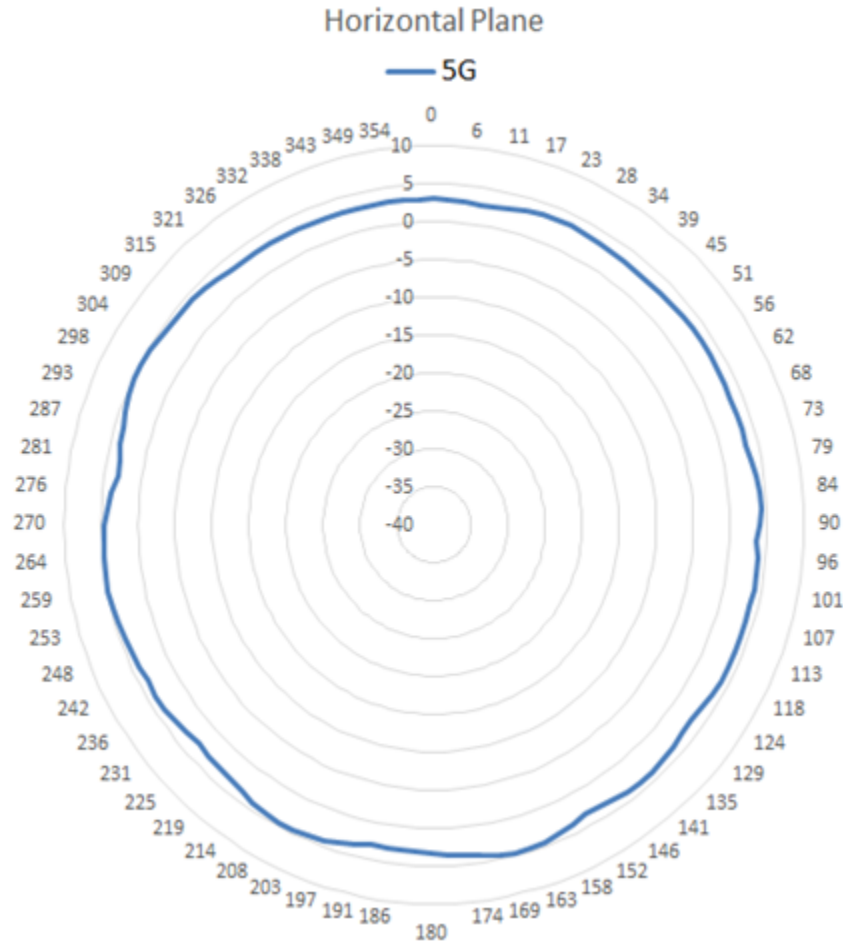


Figure 69: 5 GHz radio 2 azimuth pattern

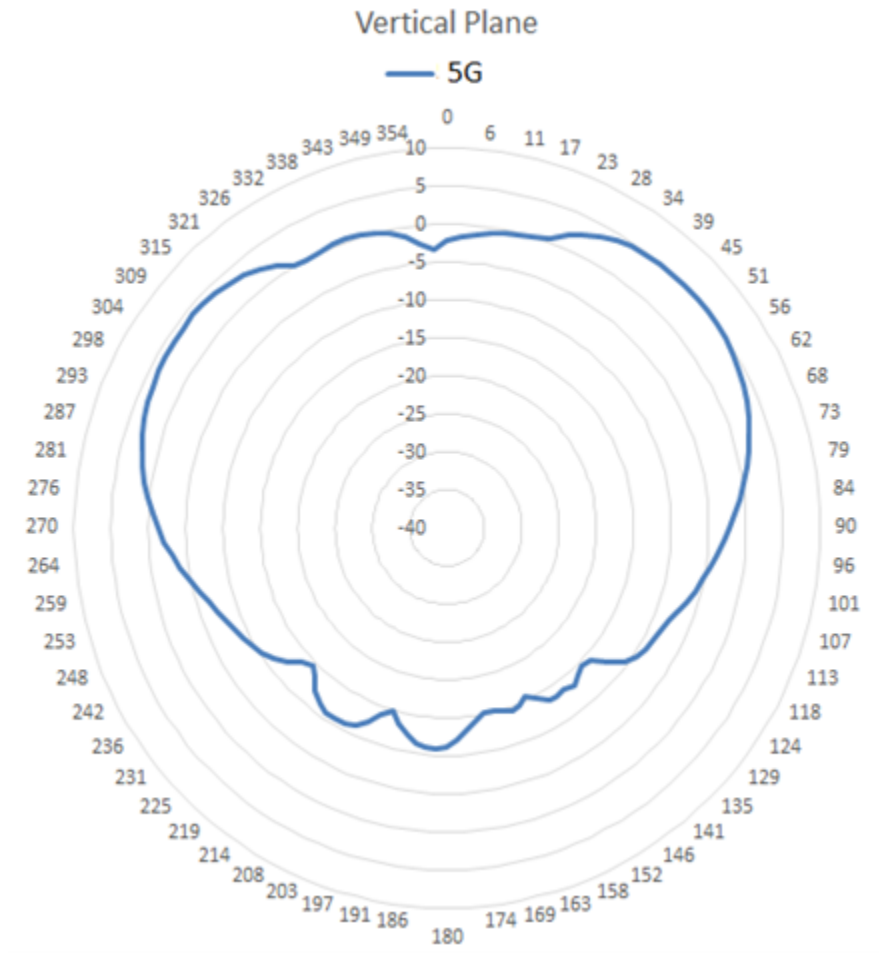


Figure 70: 5 GHz radio 2 elevation pattern

## AP560i Internal Antenna Radiation Patterns

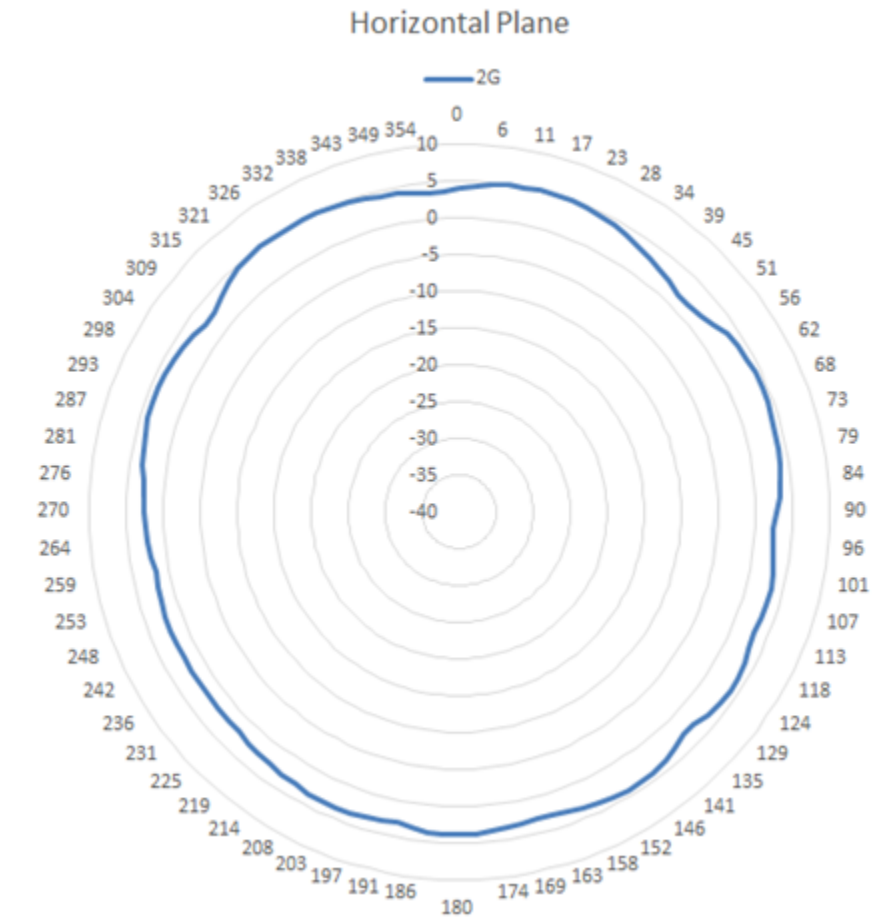
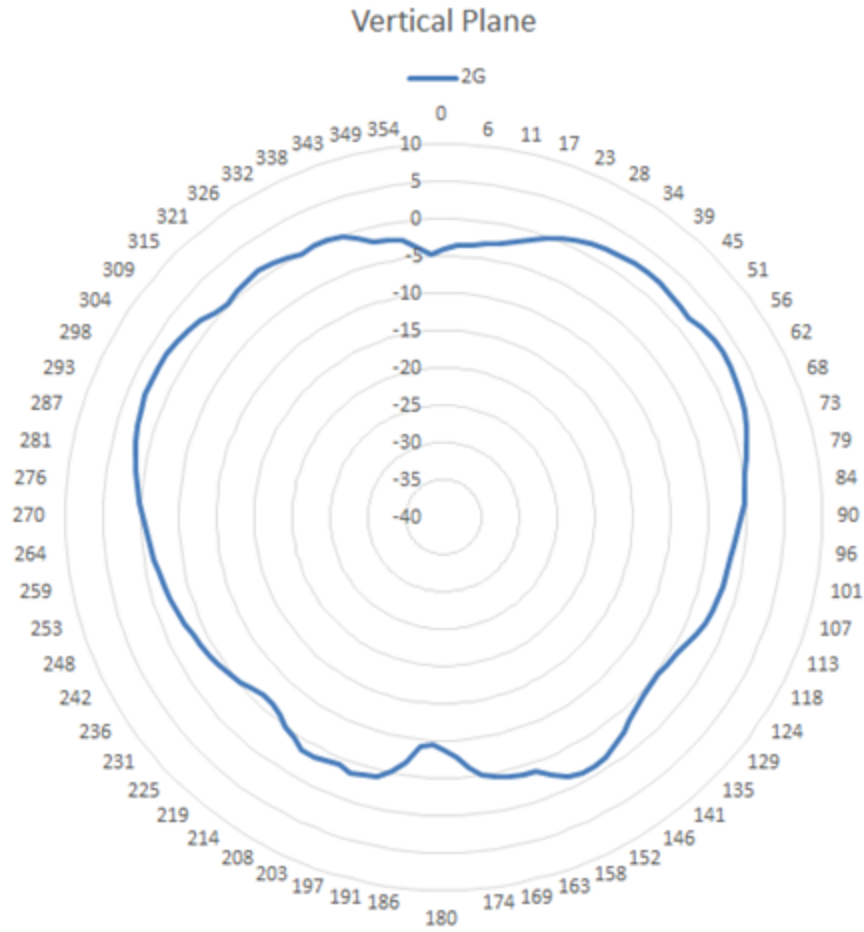
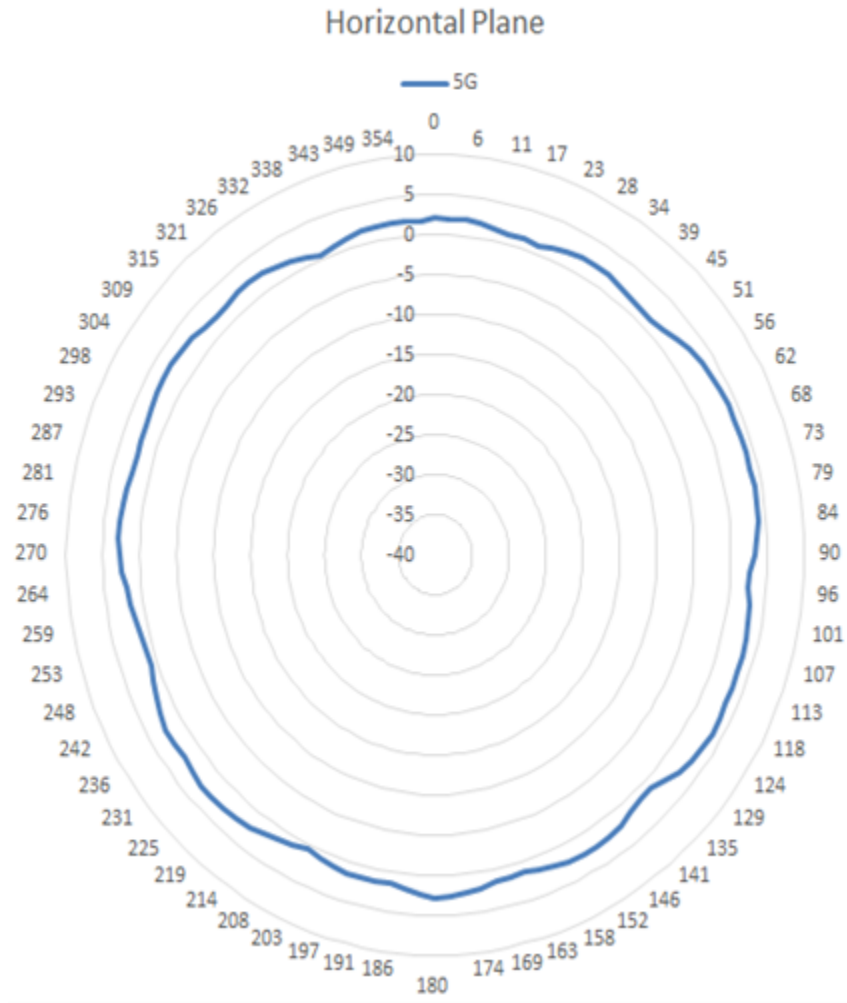


Figure 71: 2.4 GHz azimuth pattern





**Figure 72: 2.4 GHz elevation pattern**



**Figure 73: 5 GHz radio 1 azimuth pattern**

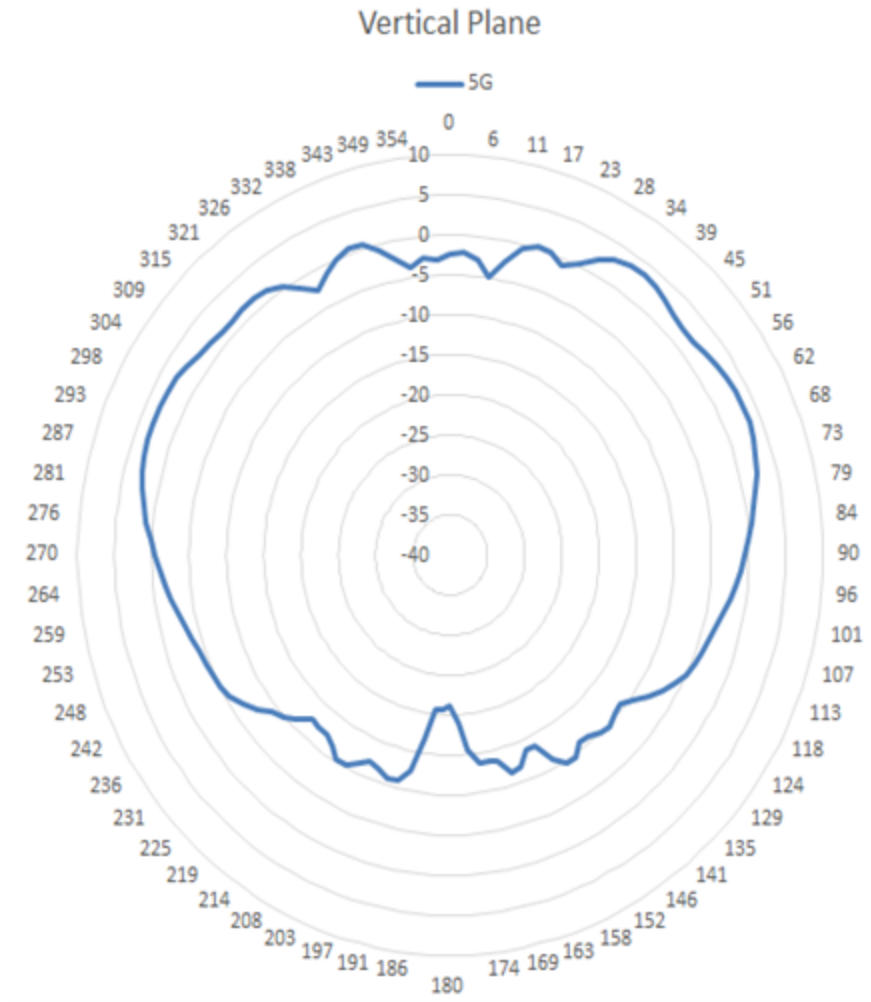
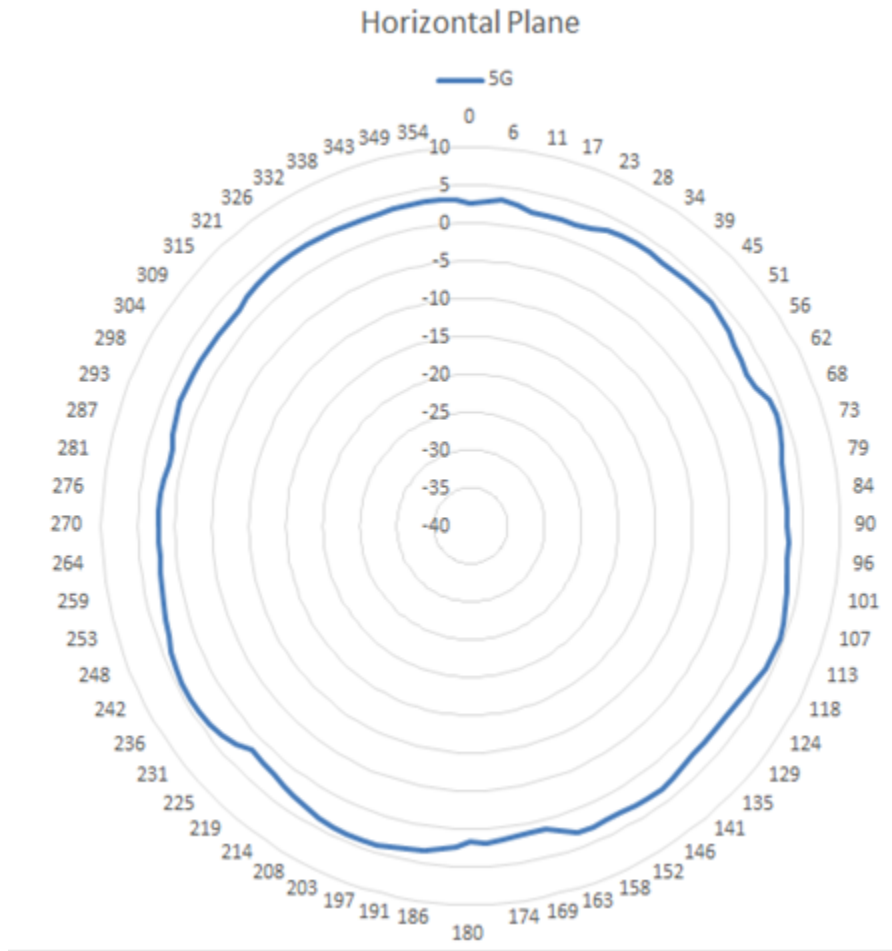


Figure 74: 5 GHz radio 1 elevation pattern



**Figure 75: 5 GHz radio 2 azimuth pattern**

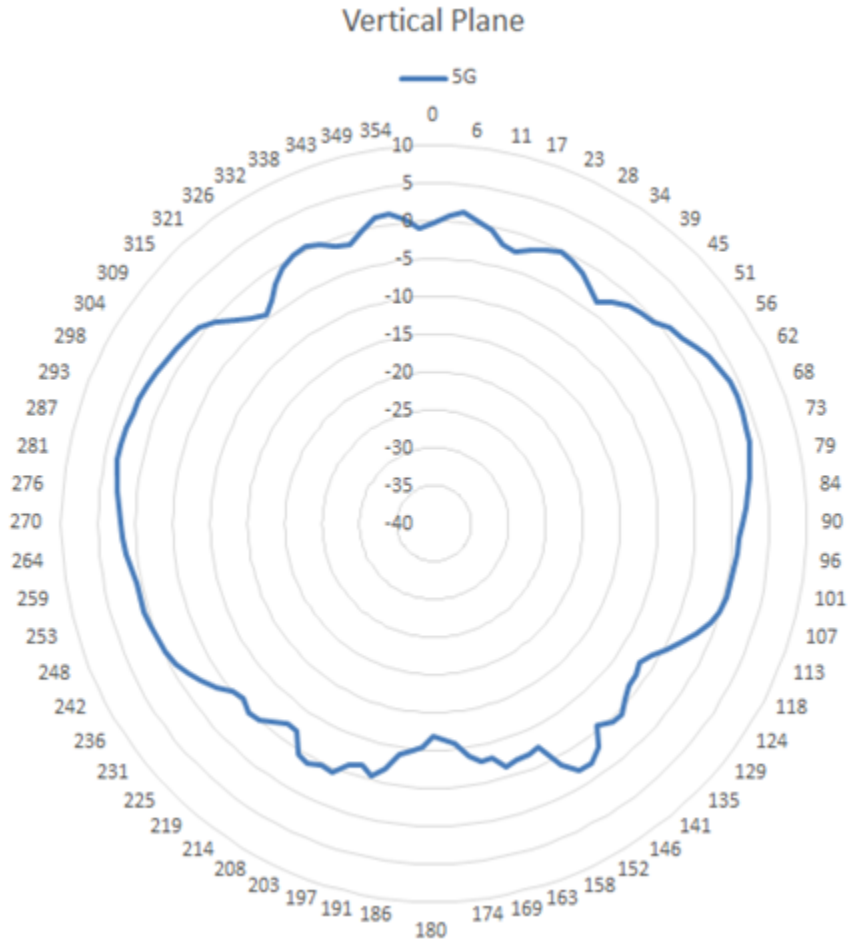


Figure 76: 5 GHz radio 2 elevation pattern



# Antenna Cables Specifications

This section lists the specifications for indoor and outdoor antenna cables.

## Indoor antenna cables with RP-SMA type connectors

The indoor cables used with the ExtremeMobility antennas use a standard RP-SMA type plug connector. The following table provides details about the cables used with the RP-SMA plug type connector:

Indoor cable details
10.00 ft (3.05 m) PFP240 cable (WS-CAB240- P10RP)
25.00 ft (7.62 m) PFP240 cable (WS-CAB240- P25RP)

**Table 51: WS-CAB240-P10RP and WS-CAB240-P25RP cable specifications**

Specification	Value
Mechanical	
Length	WS-CAB240-P10RP: 10.00 ft (3.05 m) WS-CAB240-P25RP: 25.00 ft (7.62 m)
Weight	0.002 lb/ft (0.03 kg/m)
Bend radius	0.5 in (12.7 mm)
Tensile strength	40.0 lb (18.2 kg)
Environmental	
Temperature range	Operating: -40°C to +85°C (-40°F to +185°F) Storage: -70°C to +85°C (-94°F to +185°F)
Electrical	
Cutoff frequency	39 GHz
Velocity propagation	83%
Shielding effectiveness	Greater than 90 dBi
DC resistance	Inner Conductor: 5.36 ohms/1000 ft (17.60 ohms/km) Outer Conductor: 4.9 ohms/1000 ft (16.1 ohms/km)
Peak power	2.5 kW

**Table 51: WS-CAB240-P10RP and WS-CAB240-P25RP cable specifications (continued)**

Specification	Value
Connector type	Outdoor antennas support optional cables with standard polarity type-N plug and type-N jack. Indoor antennas support optional cables with standard RP-SMA type plug connectors.
Cable loss	2.4 GHz: 3.3 dB 5.3 GHz: 5.0 dB 5.8 GHz: 5.3 dB

## Outdoor antenna cables with standard N-type plug and jack connectors

The outdoor cables used with the ExtremeMobility antennas use a type-N plug and type-N jack; therefore, the part numbers end with "N". The cables used with N-type antenna connectors are listed in the following table:

Outdoor cable details
20.00 ft (6.10 m) PFP240 cable (WS-CABL200C20N)
6.00 ft (1.83 m) PFP400 cable (WS-CABL400C06N)
20.00 ft (6.10 m) PFP400 cable (WS-CABL400C20N)
50.00 ft (15.24 m) PFP400 cable (WS-CABL400C50N)
75.00 ft (22.00 m) PFP400 cable (WS-CABL400C75N)
25.00 ft (7.60 m) PFP600 cable (WS-CABL600C25N)
50.00 ft (15.24 m) PFP600 cable (WS-CABL600C50N)

**Table 52: WS-CABL200C20N cable specifications**

Specification	Value
Mechanical	
Length	20.00 ft (6.10 meters)
Weight	0.002 lb/ft (0.03 kg/m)
Bend radius	0.5 in (12.7 mm)
Tensile strength	40.0 lb (18.2 kg)
Environmental	
Temperature range	Operating: -40°C to +85°C (-40°F to +185°F) Storage: -70°C to +85°C (-94°F to +185°F)
Electrical	
Cutoff frequency	39 GHz
Velocity propagation	83%

**Table 52: WS-CABL200C20N cable specifications (continued)**

Specification	Value
Shielding effectiveness	Greater than 90 dBi
DC resistance	Inner Conductor: 5.36 ohms/1000ft (17.6 ohms/km) Outer Conductor: 4.9 ohms/1000ft (16.1 ohms/km)
Peak power	2.5 kW
Connector type	Outdoor antennas support optional cables with standard polarity type-N plug and type-N jack. Indoor antennas support optional cables with standard RP-SMA type plug connectors.
Cable loss	2.4 GHz: 3.3 dB 5.3 GHz: 5.0 dB 5.8 GHz: 5.3 dB

**Table 53: WS-CAB-L400C06N, WS-CAB-L400C20N, WS-CAB-L400C50N, and WS-CAB-L400C75N cable specifications**

Specification	Value
Mechanical	
Length	WS-CAB-L400C06N: 6.00 ft (1.83 m) WS-CAB-L400C20N: 20.00 ft (6.10 m) WS-CAB-L400C50N: 50.00 ft (15.24 m) WS-CAB-L400C75N: 75.00 ft (22.00 m)
Weight	0.068 lb/ft (0.10 kg/m)
Bend radius	1.00 in (25.40 mm)
Tensile strength	160.0 lb (72.6 kg)
Environmental	
Temperature range	Operating: -40°C to +85°C (-40°F to +185°F) Storage: -70°C to +85°C (-94°F to +185°F)
Electrical	
Cutoff frequency	16.2 GHz
Velocity propagation	85%
Shielding effectiveness	Greater than 90 dBi
DC resistance	Inner Conductor: 1.39 ohms/1000 ft (4.6 ohms/km) Outer Conductor: 1.65 ohms/1000 ft (5.4 ohms/km)
Peak power	16 kW



**Table 53: WS-CAB-L400C06N, WS-CAB-L400C20N, WS-CAB-L400C50N, and WS-CAB-L400C75N cable specifications (continued)**

Specification	Value
Connector type	Outdoor antennas support optional cables with standard polarity type-N plug and type-N jack.
Cable loss	50.00 ft: <ul style="list-style-type: none"> <li>• 2.4 GHz: 3.3 dB</li> <li>• 5.3 GHz: 5.2 dB</li> <li>• 5.8 GHz: 5.4 dB</li> </ul> 75.00 ft: <ul style="list-style-type: none"> <li>• 2.4 GHz: 5.0 dB</li> <li>• 5.3 GHz: 7.7 dB</li> <li>• 5.8 GHz: 8.1 dB</li> </ul>

**Table 54: WS-CAB-L600C25N and WS-CAB-L600C50N cable specifications**

Specification	Value
Mechanical	
Length	WS-CAB-L600C25N: 25.00 ft (7.60 m) WS-CAB-L600C50N: 50.00 ft (15.24 m)
Weight	0.131 lb/ft (0.200 kg/m)
Bend radius	1.50 in (38.10 mm)
Tensile strength	350.0 lb (158.9 kg)
Environmental	
Temperature range	Operating: -40°C to +85°C (-40°F to +185°F) Storage: -70°C to +85°C (-94°F to +185°F)
Electrical	
Cutoff frequency	10.3 GHz
Velocity propagation	87%
Shielding effectiveness	Greater than 90 dBi
DC resistance	Inner Conductor: 0.53 ohms/1000 ft (1.70 ohms/km) Outer Conductor: 1.20 ohms/1000 ft (3.90 ohms/km)
Peak power	40 kW

**Table 54: WS-CAB-L600C25N and WS-CAB-L600C50N cable specifications (continued)**

Specification	Value
Connector type	Outdoor antennas support optional cables with standard polarity type-N plug and type-N jack.
Cable loss	25.00 ft: <ul style="list-style-type: none"> <li>• 2.4 GHz: 1.1 dB</li> <li>• 5.3 GHz: 1.7 dB</li> <li>• 5.8 GHz: 1.8 dB</li> </ul> 50.00 ft: <ul style="list-style-type: none"> <li>• 2.4 GHz: 2.2 dB</li> <li>• 5.3 GHz: 3.5 dB</li> <li>• 5.8 GHz: 3.6 dB</li> </ul>



# Antenna Installation Information

---

[Install the ML-2452-APA2-01 or ML-2452-APA2-02 Antenna on page 100](#)

[Install the ML-2452-HPA5-036 Antenna on page 101](#)

[Install the ML-2452-HPA6-01 Antenna on page 110](#)

[Install the ML-2452-HPAG4A6-01 Antenna on page 110](#)

[Install the ML-2452-HPAG5A8-01 Antenna on page 111](#)

[Install the ML-2452-PTA4M4-036 Antenna on page 114](#)

[Install the ML-2452-PNA5-01R Antenna on page 115](#)

[Install the ML-2452-SEC6M4-036 Antenna on page 122](#)

[Install the ML-2452-PNA7-01R Antenna on page 125](#)

[Install the AI-DQ04360S Antenna on page 129](#)

[Install the WS-AI-DQ05120, WS-AI-DE07025, or WS-AI-DE10055 Antenna on page 137](#)

[Install the WS-AO-DQ04360N Antenna on page 143](#)

## Antenna Installation Best Practices

---

Antennas transmit and receive radio signals which are susceptible to Radio Frequency (RF) obstructions and common sources of interference that can reduce the throughput and range of the device to which they are connected. Follow these guidelines to ensure the best possible antenna performance:

- Install the antenna vertically and mount it with the cables pointing toward the ground.
- Keep the antenna away from metal obstructions such as heating and air-conditioning ducts, large ceiling trusses, building superstructures, and major power cabling runs. If necessary, use a rigid conduit to lower the antenna away from these obstructions.
- The building construction material density determines the number of walls the signal can pass through and still maintain adequate signal strength.
- Consider the following before choosing the location for your antenna:
  - Signals penetrate paper and vinyl walls with little change to signal strength.
  - Signals penetrate only one or two solid and pre-cast concrete walls without degrading signal strength.
  - Signals penetrate three or four concrete and wood block walls without degrading signal strength.
  - Signals penetrate five or six drywall or wood wall without degrading signal strength.

- Signals will reflect off thick metal wall and will not penetrate it at all.
- Signals will reflect off a chain link fence or wire mesh spaced between 1 and 1.5 inches (2.5 and 3.8 cm).

The fence acts as a harmonic reflector that blocks the signal.

- Install the antenna away from microwave ovens and 2 GHz cordless phones.

These products can cause signal interference because they operate in the same frequency range as the device to which your antenna is connected.

## Install the ML-2452-APA2-01 or ML-2452-APA2-02 Antenna

---

### About This Task

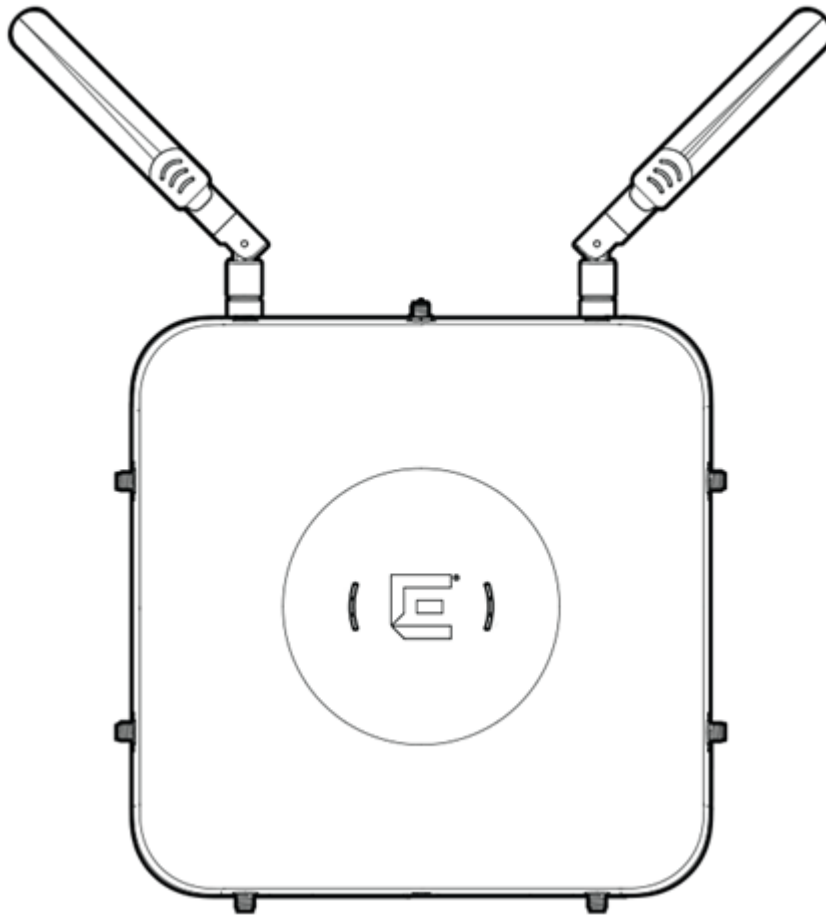
After you install the indoor access point, install the ML-2452-APA2-01 or ML-2452-APA2-02 antenna.

### Procedure

1. Line up the antenna connector and the antenna port on the access point.

Refer to [External Antenna Connectors](#) topic for information on antenna connector on various access points.

2. Twist the antenna connector clockwise to attach it to the antenna port.



**Figure 77: ML-2452-APA2-01 or ML-2452-APA2-02 antenna attached to the AP510e access point**

#### Related Topics

[ML-2452-APA2-01 and ML-2452-APA2-02 Antenna Specifications and Radiation Patterns](#) on page 24

## Install the ML-2452-HPA5-036 Antenna

### About This Task

The ML-2452-HPA5-036 is an omnidirectional antenna used for 2.4 GHz and 5.0 GHz RF-distribution systems. The antenna can be attached on an I-beam clamp, a mast or a pole, or to a ceiling.



#### Warning

The antenna and all associated accessories must be installed in accordance with local and national electrical code guidelines to ensure safe operation.

The following accessories are required for various installations, and must be purchased separately.

- One ceiling mount adapter plate
- Two #6-32 × ¼ in. stainless steel (SS) screws

- Two #6 internal tooth lock washers
- One ¼ in. internal tooth lock washer
- One ceiling hanger bracket
- One 5/16-18 U-bolt
- Four 5/16 in. ss lock washers
- Six 5/16-18 ss hex nuts
- Two omni clamps
- One mast clamp
- Two 5/16 SS flat washers
- One ¼ SS flat washer
- One I-beam clamp
- One 1/4-20 × ½ SS hex head

## ML-2452-HPA5-036 Antenna Ceiling Install

### About This Task

The antenna is mounted on the ceiling using the ceiling hardware accessories.



#### Tip

The best practice is to mount the antenna on a ceiling or roof-level near the center of the coverage area.

The following hardware is required for installing the antenna on a ceiling:

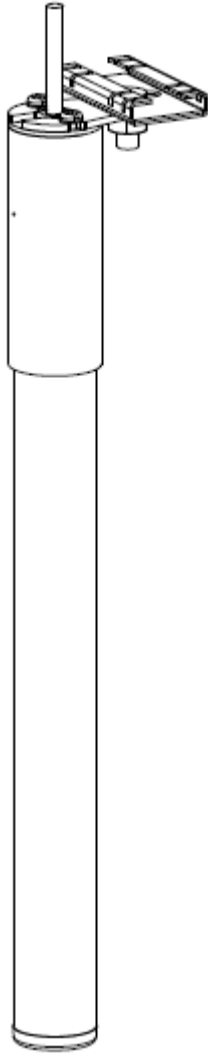
- Ceiling mount adapter plate
- Two, #6 internal tooth lock washers
- Two, #6-32 × ¼ in. SS screws
- ¼ in. internal tooth lock washer
- Ceiling hanger (grid) bracket
- 5/16 - 18 SS hex nut

### Procedure

1. Attach the ceiling mount adapter plate to the antenna using two SS screws and two #6 internal tooth lock washer.
2. Remove the ¼ in. - 20 hex nut and flat washer from the ceiling hanger bracket.  
Discard the flat washer since it will not be used during installation.
3. Insert the ceiling hanger bracket into the edge hole on the ceiling mount adapter plate.

4. Attach the ceiling hanger bracket to the ceiling mount adapter plate using the  $\frac{1}{4}$  in. -20 hex nut and the  $\frac{1}{4}$  in. internal tooth lock washer.

The tooth lock washer must be loosely attached to the  $\frac{1}{4}$  in. hex nut.



**Figure 78: ML-2452-HPA5-036 antenna with the ceiling hanger bracket installed**

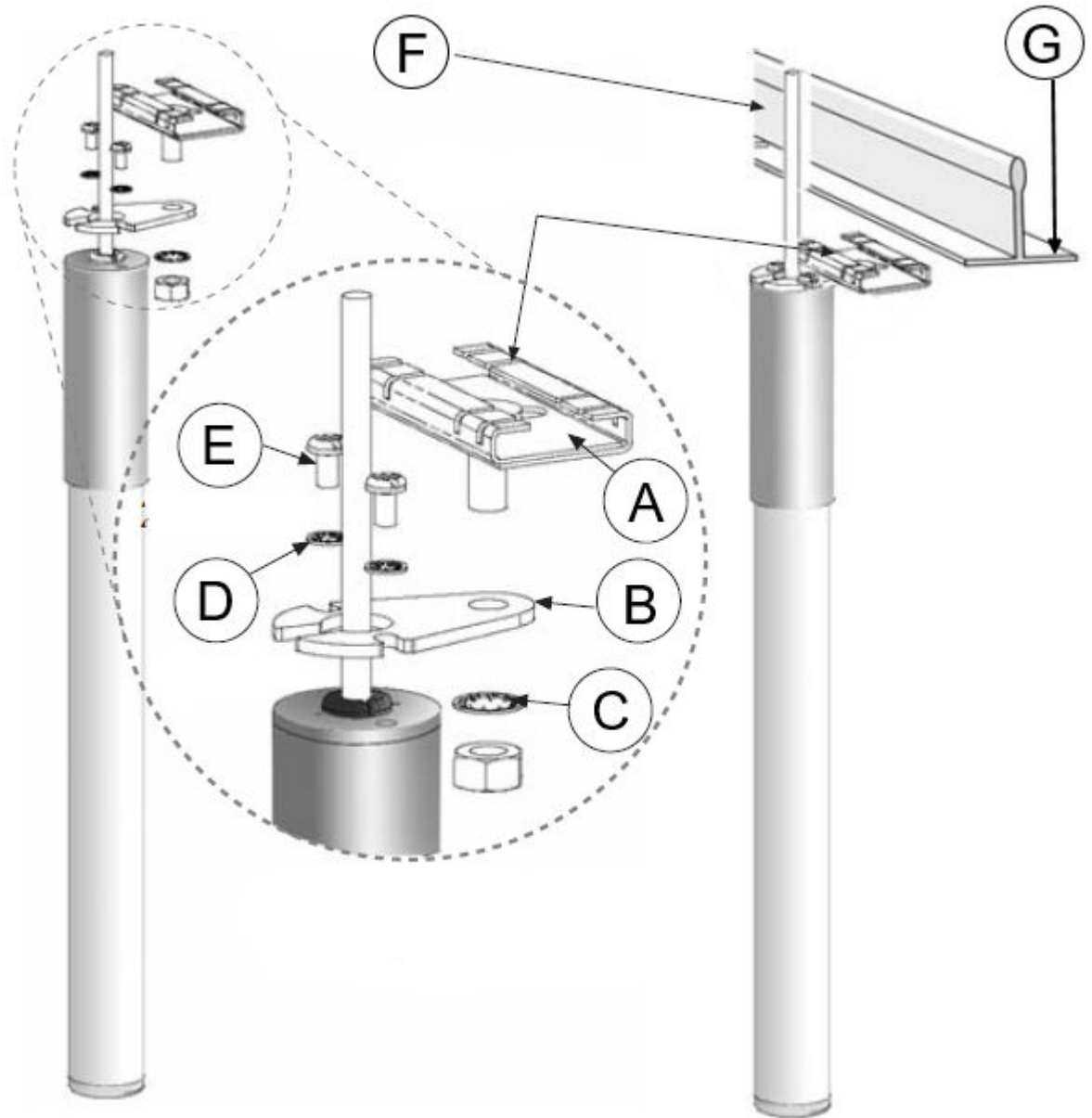
5. Place the ceiling hanger bracket on a ceiling tile runner.
6. Insert the  $\frac{5}{16}$  - 8 SS hex nut on the  $\frac{1}{4}$  in. - 20 hex nut and tighten it using a  $\frac{7}{16}$  in. wrench.
7. Secure the LMR cable along the ceiling runner using a tape or cable ties.



**Note**

You need to provide the tape or cable ties.

8. Attach the antenna connector to the access point connector.



**Figure 79: MP-2452-HPA5-036 antenna ceiling installation procedure**

Callout	Description
A	Ceiling hanger bracket
B	Ceiling mount adapter plate
C	1/4 in. internal tooth lock washer and 5/16 - 8 SS hex nut
D	#6 internal tooth lock washer
E	#6-32 x 1/4" SS screw



Callout	Description
F	Ceiling support runner
G	Ceiling support runner area for attaching the ceiling hanger bracket

## ML-2452-HPA5-036 Antenna I-beam Install

### About This Task

The antenna is attached to an I-beam using the bracket plate and other hardware accessories.

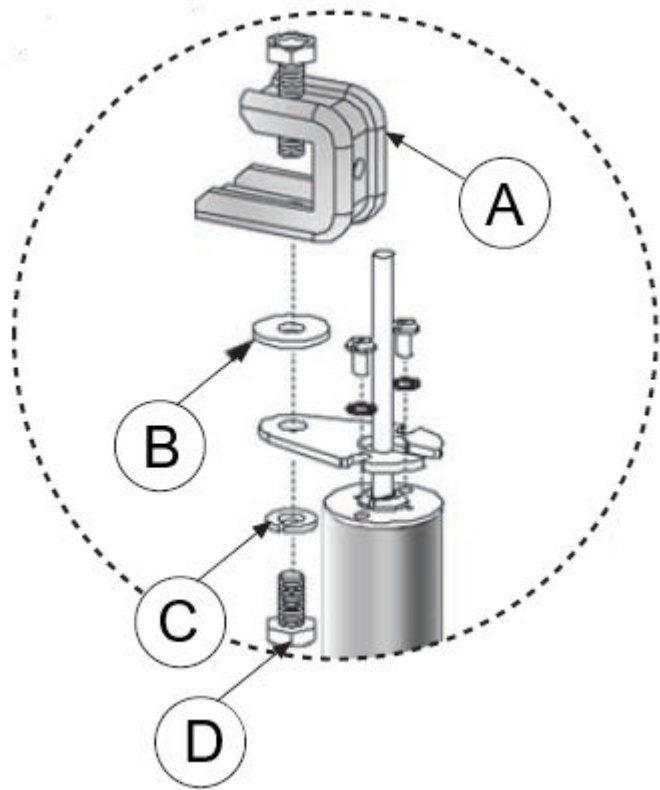
Hardware required for installing the antenna on an I-beam:

- Ceiling mount adapter plate
- Two, #6 internal tooth lock washers
- Two, #6-32 × ¼ in. SS screws
- I-beam clamp
- ¼ in. SS flat washer
- ¼ in. SS lock washer (also known as split washer)
- ¼-20 × ½ SS hex-head

### Procedure

1. Attach the ceiling mount adapter plate to the antenna using two #6 int. tooth lock washers and two #6-32 × ¼ in. SS screws.

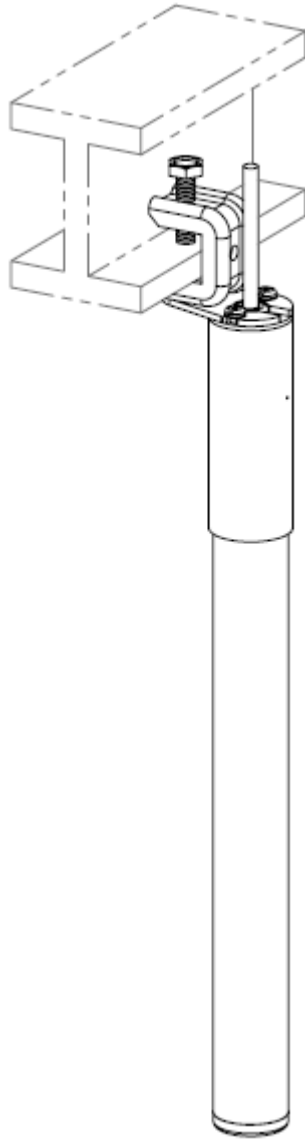
2. Install the I-beam clamp to the adapter plate using the ¼ in. SS flat washer, ¼ in. SS lock washer, and the ¼ -20 × ½ SS hex-head as shown in the following figure.



**Figure 80: ML-2452-HPA5-036 antenna I-beam install procedure**

Callout	Description
A	I-beam clamp
B	¼ in. SS flat washer
C	¼ in. SS lock washer
D	¼ -20 × ½ SS hex-head

3. Tighten the clamp bolt to secure the antenna in place on the beam.



**Figure 81: ML-2452-HPA5-036 antenna installed on an I-beam**

## ML-2452-HPA5-036 Antenna Pole or Mast Install

### About This Task

The antenna is installed to a pole or to a mast using pole mount bracket and other hardware accessories.

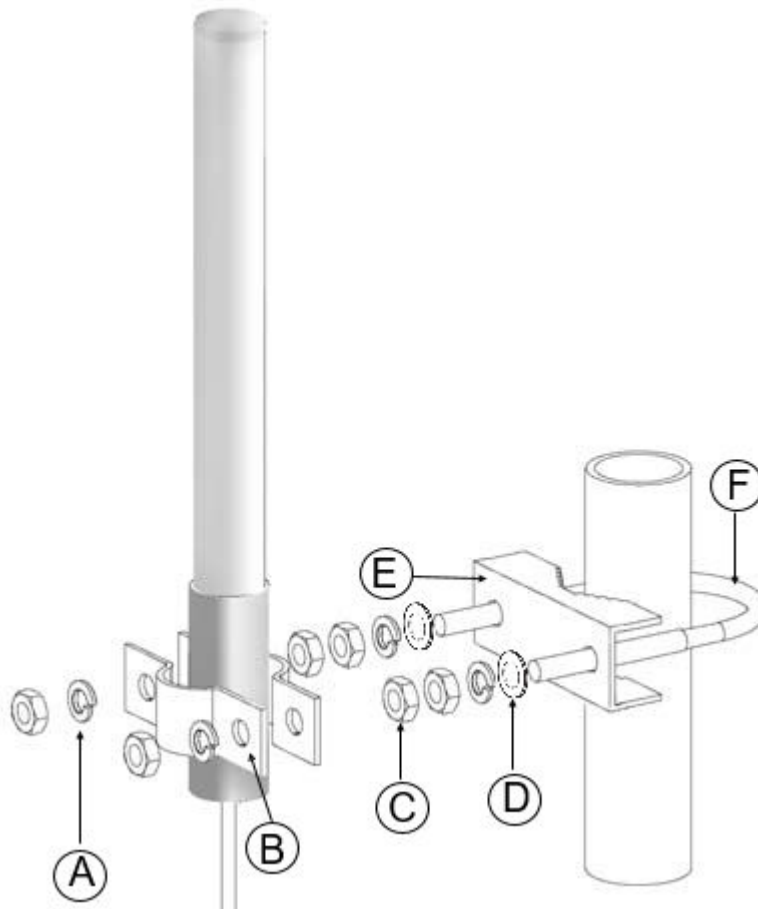
Hardware required for installing the antenna on a pole:

- Four, 5/16 in. SS lock washers
- Two omni clamps (also called base bracket)
- Six, 5/16 in. – 18 SS hex nuts
- Two, 5/16 in. SS flat washers

- One mast clamp (also called V-bracket)
- One, 5/16 in. - 18 U-bolt

### Procedure

1. Place the 5/16 in. - 18 U-bolt and the mast clamp on a pole or mast and attach it using two flat washers, two lock washers, and four hex nuts as shown in the following [figure](#).



**Figure 82: ML-2452-HPA5-036 pole or mast install using pole mounting hardware accessories**

Callout	Description
A	5/16 in. SS lock washer
B	Omni clamp (also called base bracket)
C	5/16 in. - 18 SS hex nuts
D	5/16 in. SS flat washers
E	Mast clamp (also called V-bracket)
F	5/16 in. - 18 U-bolt

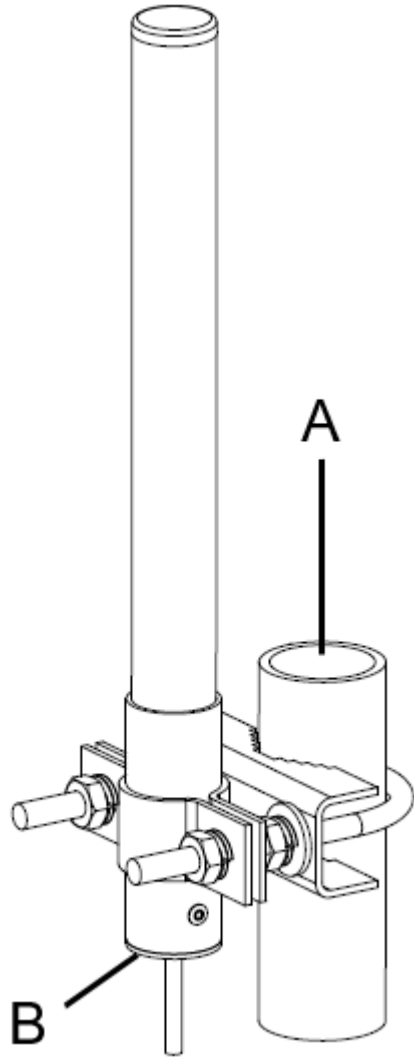
2. Attach the omni clamps around the antenna and slide it on to the U-bolt.
3. Secure the antenna on the U-bolt using two, 5/16 in. SS lock washers and two 5/16 in.-18 SS hex nuts.

4. Secure the LMR cable along the mast or the pole using tape or cable ties.



**Note**

If you are mounting the antenna outside or in a wet environment, ensure that the antenna is vertically mounted with the weep holes facing down.



**Figure 83: ML-2452-HPA5-036 antenna installed on a pole**

Callout	Description
A	Pole
B	ML-2452-HPA5-036 antenna

Related Topics

[ML-2452-HPA5-036 Antenna Specifications and Radiation Patterns](#) on page 28

---

## Install the ML-2452-HPA6-01 Antenna

---

### About This Task

The ML-2452-HPA6-01 is a four feed, dual band outdoor antenna with a standard N-type plug connector. The antenna can be attached directly to the access point.

### Procedure

1. Line up the antenna connector against the antenna port on the access point.
2. Twist the antenna connector clockwise to attach it to the antenna port.

Related Topics

[ML-2452-HPA6-01 Antenna Specifications and Radiation Patterns](#) on page 33

---

## Install the ML-2452-HPAG4A6-01 Antenna

---

### About This Task

The ML-2452-HPAG4A6-01 is an omnidirectional, co-linear, and vertically polarized antenna used with indoor and outdoor access points. An integrated RF connector is embedded in the antenna base cap for direct access point mounting. The antenna comes with a vent area that permits either upright or inverted orientation for outdoor installations.

If the antenna cannot be mounted directly on the access point, it must be mounted to a pole.



#### Warning

Do not mount the antenna next to a column or vertical support since it creates a shadow zone of reduced coverage to one portion of the room.

## ML-2452-HPAG4A6-01 Antenna Direct Attach

### Procedure

1. Line up the antenna connector against the access point antenna port.
2. Twist the antenna connector clockwise to attach it to the antenna port.

## ML-2452-HPAG4A6-01 Antenna Pole Install

### About This Task

The antenna is mounted on a pole if the antenna connector cannot be directly attached to the access point connector.

The following hardware is required for installing the antenna on a pole:

- One mast clamp
- One pole clamp with screws

### Procedure

1. Attach the mast clamp to the antenna using the pole clamp.
2. Place the mast clamp assembly and the antenna to a pole.

3. Tighten the clamp screws on the pole clamp.



**Figure 84: ML-2452-HPAG4A6-01 antenna mounted on a pole**

4. Install a ground rod.



**Tip**

A ground rod is used to drain off static electricity build-up.

5. Connect the ground wire to the pole and the ground rod.

Related Topics

[ML-2452-HPAG4A6-01 Antenna Specifications and Radiation Patterns](#) on page 36

## Install the ML-2452-HPAG5A8-01 Antenna

### About This Task

The ML-2452-HPAG5A8-01 is an omnidirectional, co-linear, and vertically polarized antenna used with indoor and outdoor access points. An integrated RF connector is embedded in the antenna base cap for

direct access point mounting. The antenna comes with a vent area that permits either upright or inverted orientation for outdoor installations.

If the access point has an integrated male or female N-connector, the antenna can be directly attached to the access point. If the antenna cannot be mounted directly on the access point, it must be mounted to a pole.

**Warning**

Do not mount the antenna next to a column or vertical support since it creates a shadow zone of reduced coverage to one portion of the room.

## ML-2452-HPAG5A8-01 Antenna Direct Attach

**Procedure**

1. Line up the antenna connector against the access point antenna port.
2. Twist the antenna connector clockwise to attach it to the antenna port.

The sealing on the antenna connector permits upright or inverted orientation during outdoor mounting.

## ML-2452-HPAG5A8-01 Antenna Pole Install

**About This Task**

The antenna is mounted on a pole if the antenna connector cannot be directly attached to the access point connector.

The following hardware is required for installing the antenna on a pole:

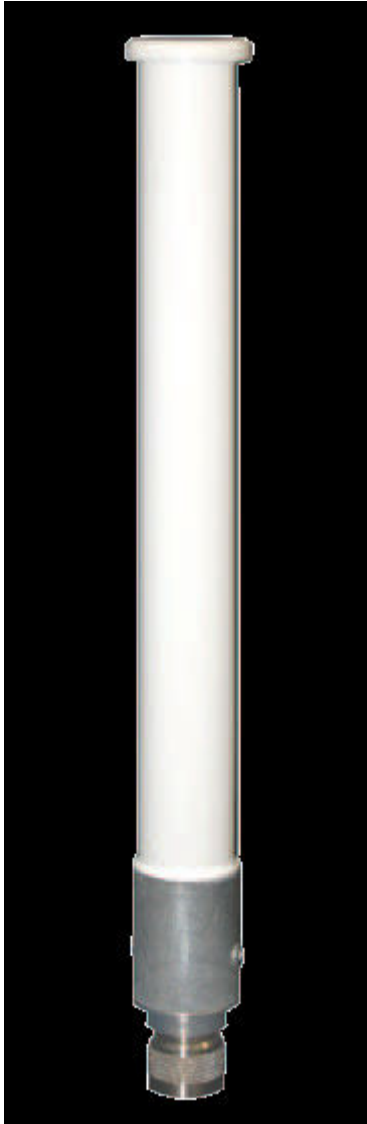
- One mast clamp
- One pole clamp with screws

**Procedure**

1. Attach the mast clamp to the antenna using the pole clamp.
2. Place the mast clamp assembly and the antenna to a pole.



3. Tighten the clamp screws on the pole clamp.



**Figure 85: ML-2452-HPAG5A8-01 antenna**

4. Install a ground rod.



**Tip**

A ground rod is used to drain off static electricity build-up.

5. Connect the ground wire to the pole and the ground rod.

Related Topics

[ML-2452-HPAG5A8-01 Antenna Specifications and Radiation Patterns](#) on page 39

---

## Install the ML-2452-PTA4M4-036 Antenna

---

### About This Task

The ML-2452-PTA4M4-036 antenna is designed for wireless LAN (WLAN) application system requirements covering a wide range of operating frequency.



#### Tip

The best practice is to mount the antenna near the center of the coverage area.

## ML-2452-PTA4M4-036 Antenna Ceiling Mount Procedure

### About This Task

When the antenna is mounted on a suspended ceiling, you have access to both the sides of the mounting surface. During this installation, the best practice is to use the threaded post and the mounting nut on the back of the antenna. Follow the installation procedure to securely attach the ML-2452-PTA4M4-036 antenna to a suspended ceiling.



#### Note

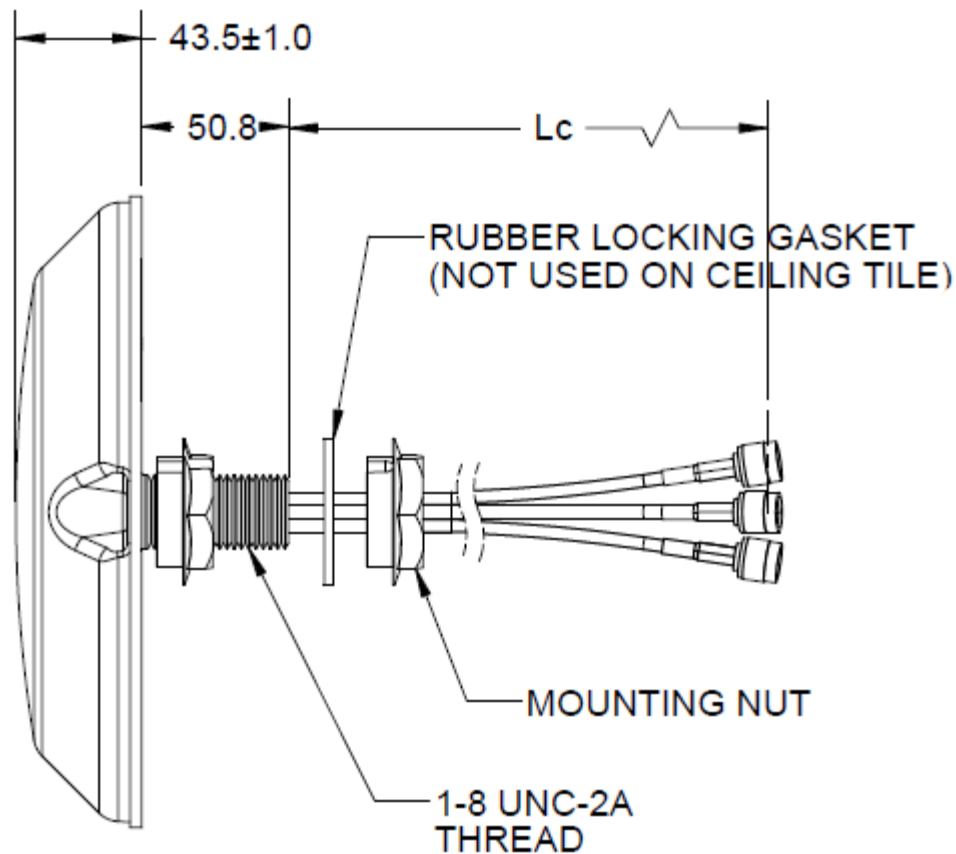
The beam clamp mounting kit is not included with the antenna, and must be purchased separately.

### Procedure

1. Remove the ceiling tile.
2. Mark and cut a 1.57 in. (40 mm) hole in the ceiling tile where the antenna threaded post and mounting nut must go through.
3. Feed the cables through the hole.

4. Secure the antenna with the mounting nut.

Use the rubber locking gasket when the antenna is mounted on a solid surface such as dry or wood wall.



**Figure 86: ML-2452-PTA4M4-036 antenna ceiling mount procedure on a suspended ceiling tile**

Related Topics

[ML-2452-PTA4M4-036 Antenna Specifications and Radiation Patterns](#) on page 43

## Install the ML-2452-PNA5-01R Antenna

### About This Task

The ML-2452-PNA5-01R antenna mounts to any flat vertical surface with wall anchors, and can be mounted to a vertical pole using the pole mount kit.

Follow this procedure to securely mount the antenna to a flat vertical surface or to a vertical pole.



Tip



The best practice is to install the antenna on a surface facing the coverage zone.

## ML-2452-PNA5-01R Antenna Flat Surface Install

### About This Task

The antenna comes with wall anchors and other necessary hardware for flat surface installation.

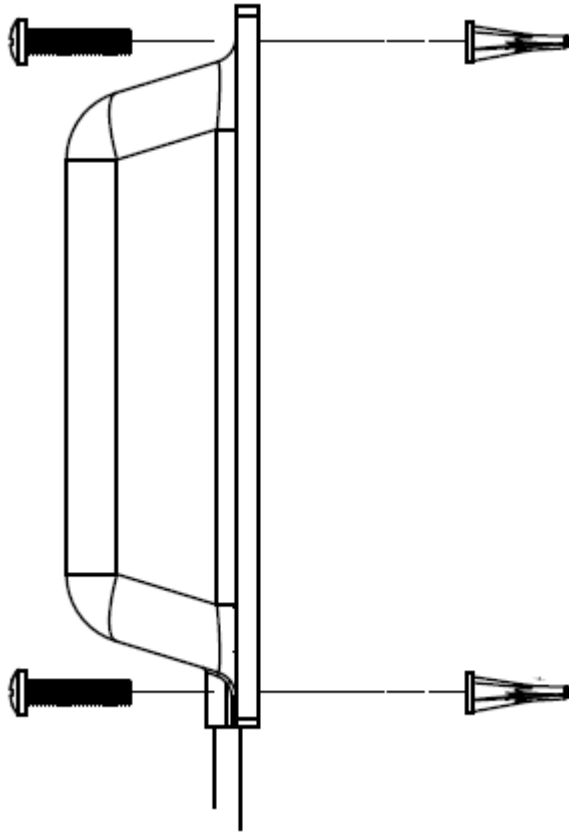
The following hardware is required for flat surface installation:

Quantity	Item	Description
2		SS self-tap machine screw
2		Plastic wall anchor

### Procedure

1. Using the antenna mounting holes as a template, mark and drill four holes on a vertical flat surface. The mounting holes must be 3/16 in. in diameter.

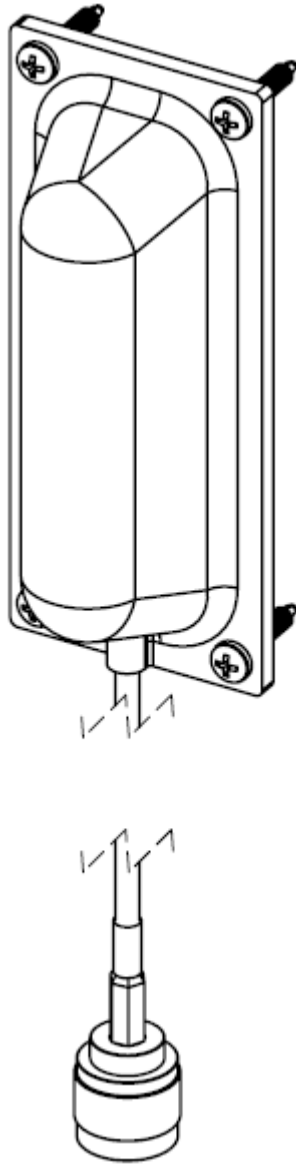
2. Insert the plastic wall anchors into the mounting holes.



**Figure 87: Antenna installation to a flat surface using the plastic anchors and the SS self-tap machine screws**

3. Place the antenna over the wall anchors and attach it to the wall using four SS self-tap machine screws.

4. Torque the screws till the antenna is held in place.





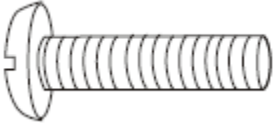
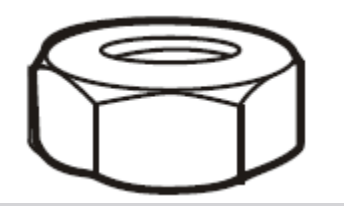
**Figure 88: ML-2452-PNA5-01R antenna installed on a vertical flat surface**

## ML-2452-PNA5-01R Antenna Pole Install

### About This Task

The antenna is mounted to a pole using the hardware that comes with the pole mounting kit. The pole width can be up to 2 in. in diameter.

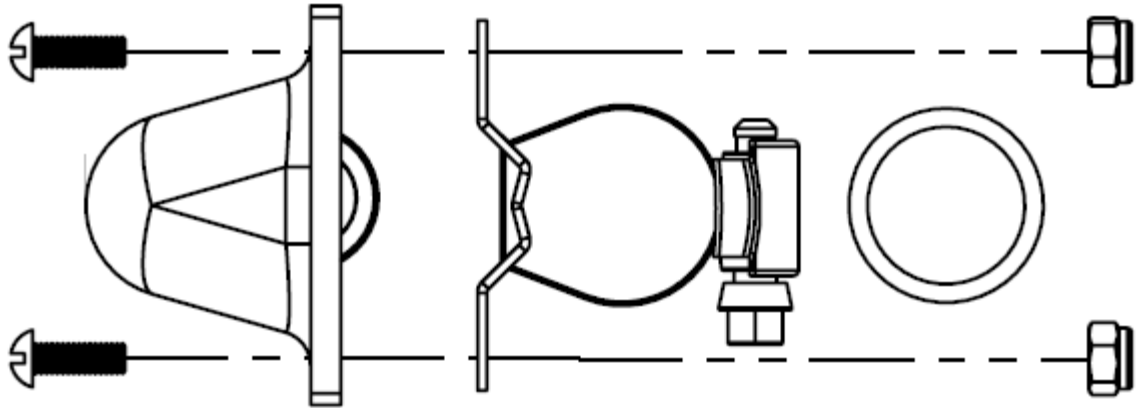
The following hardware is required for pole mount procedure:

Quantity	Item	Description
2		Hose clamp
2		MTE bracket
4		SS machine screw
4		SS nylon hex nut

**Procedure**

1. Slide the hose clamp through the MTE bracket slot.  
Do this for both the MTE brackets.
2. Place the hose clamps over the pole and tighten it clockwise.  
Do not over tighten the hose clamps.

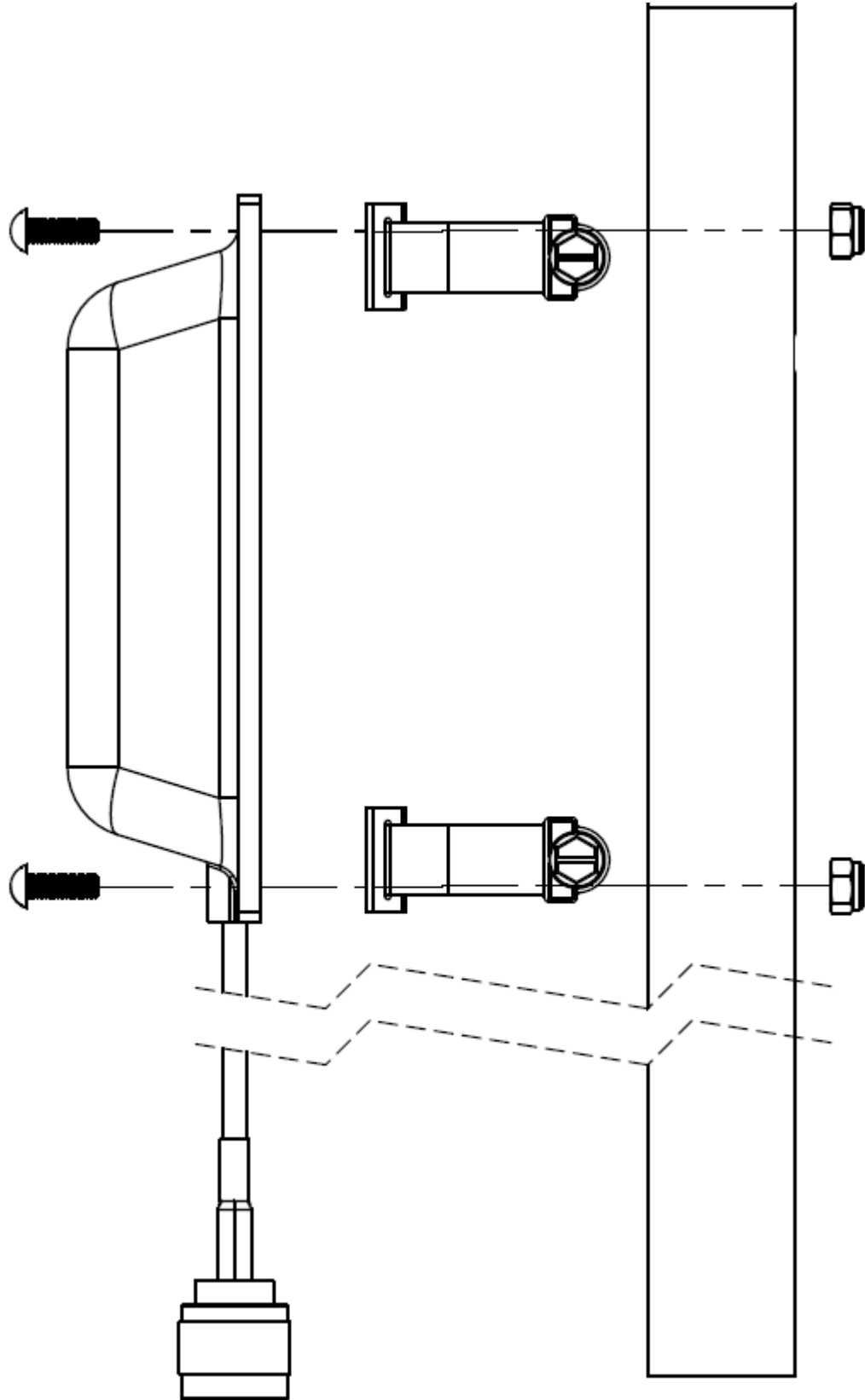
- Align the antenna, MTE bracket with the hose clamp, SS machine screw, and the SS nylon nut as shown in the following figure:



**Figure 89: Hardware parts alignment with the antenna for pole mount procedure**



4. Torque the nylon hex nuts to securely attach the antenna to the pole.



**Figure 90: ML-2452-PNA5-01R antenna pole mount procedure**

## Related Topics

[ML-2452-PNA5-01R Antenna Specifications and Radiation Patterns](#) on page 49

## Install the ML-2452-SEC6M4-036 Antenna

---

### About This Task

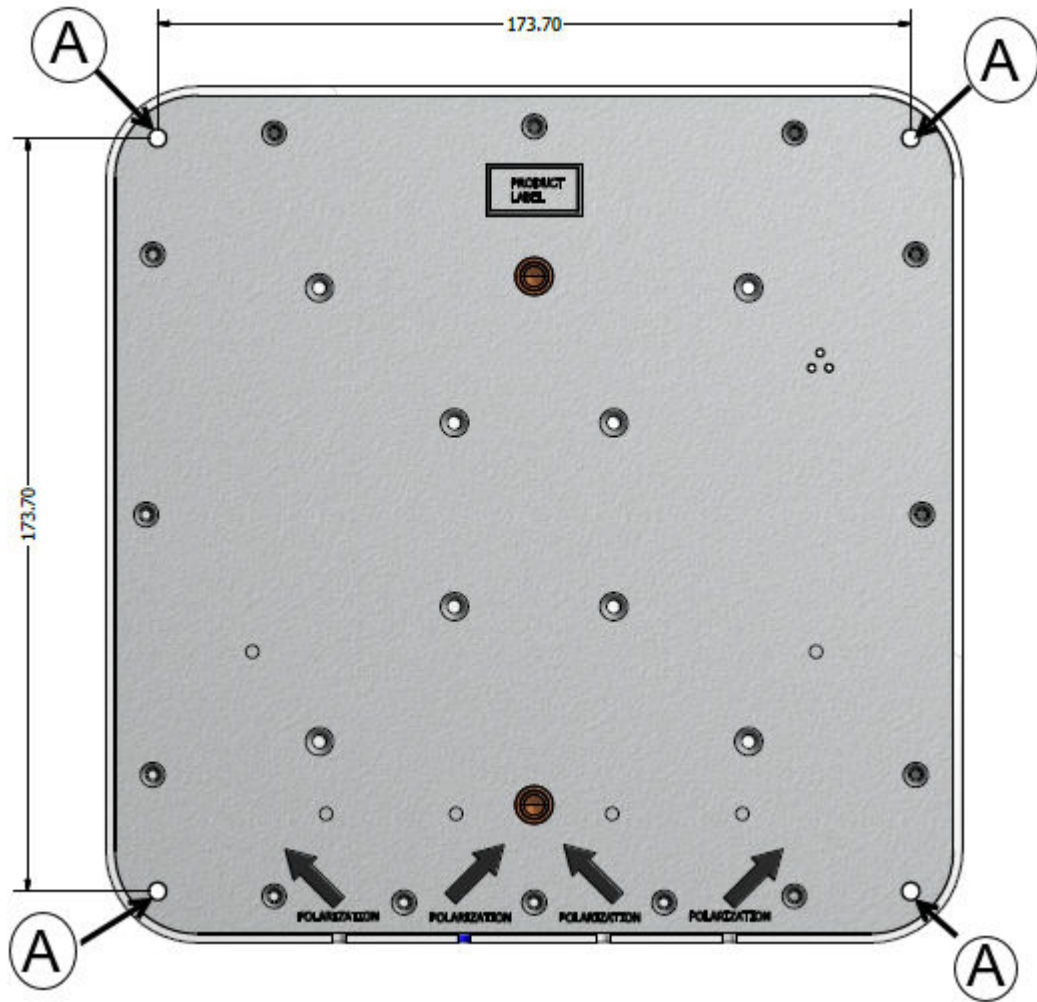
The ML-2452-SEC6M4-036 antenna is mounted to a wall.

ML-2452-SEC6M4-036 antenna box contents:

- A wall mount kit, that includes:
  - Four plastic wall insert plugs
  - Four self-tapping screws
  - Four flat washers
- One ML-2452-SEC6M4-036 antenna
- One wall mount instructions sheet
- One Waste Electrical and Electronic Equipment (WEEE) document
- One China RoHS sheet

**Procedure**

1. Using the ML-2452-SEC6M4-036 antenna holes as a template, mark and drill four, 5 × 35 mm holes on a wall.



**Figure 91: Antenna mounting holes**

Callout	Description
A	Antenna hole templates for wall mount installation

2. Insert four plastic wall insert plugs into the mounting holes.

- Place a flat washer on every antenna mounting hole template, and insert the self tapping screw through the flat washer.



Callout	Description
A	Self tapping screw
B	Flat washer



**Note**

Antenna cables are not shown in the antenna images.

- Insert the self tapping screws into the plastic wall insert plugs, and tighten the screws.



**Figure 92: Self tapping screws inserted into the plastic wall insert plugs**

## Related Topics

[ML-2452-SEC6M4-036 Antenna Specifications and Radiation Patterns](#) on page 53

## Install the ML-2452-PNA7-01R Antenna

---

### About This Task

The ML-2452-PNA7-01R is a directional patch array enclosed antenna with a UV-stable, weatherproof radome. The ML-2452-PNA7-01R antenna can be mounted at indoor or outdoor locations. It is mounted on a pole or to any flat vertical surface, and comes with a universal articulating mount for wall and pole installations.

**Tip**

The ML-2452-PNA7-01R antenna has a narrow beamwidth. The best practice is to install the antenna away from reinforced block walls, metal cabinets, and steel shelving to experience optimum gain and best performance.

## ML-2452-PNA7-01R Antenna Wall Install

### About This Task

Install the antenna on a flat vertical wall using the universal articulating mount.

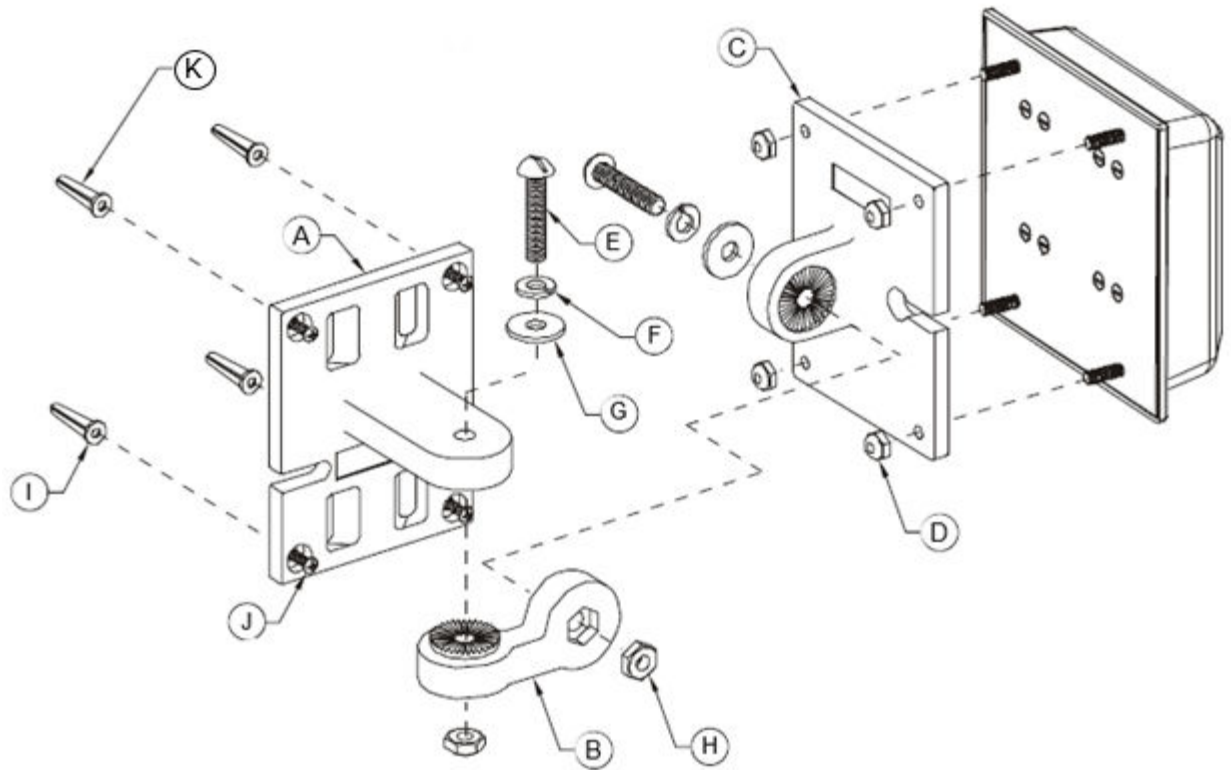
The following hardware is required for wall installation:

- One wall mount
- One articulating arm
- One antenna mount
- Four ¼ in. SS nylon hex nuts
- One machine screw
- One SS split lock washer
- One ¼ in. flat washer
- One ¼ in. - 20 SS hex nut
- Four #8 plastic wall anchors
- Four #8-18 × ¾ in. SS machine screws

### Procedure

1. Attach the antenna mount to the exposed studs on the antenna using four ¼ in. SS nylon hex nuts.

2. Attach the articulating arm to the antenna mount using the machine screw, SS split lock washer, ¼ in. flat washer, and ¼ in. - 20 SS hex nut, as shown in the following figure.

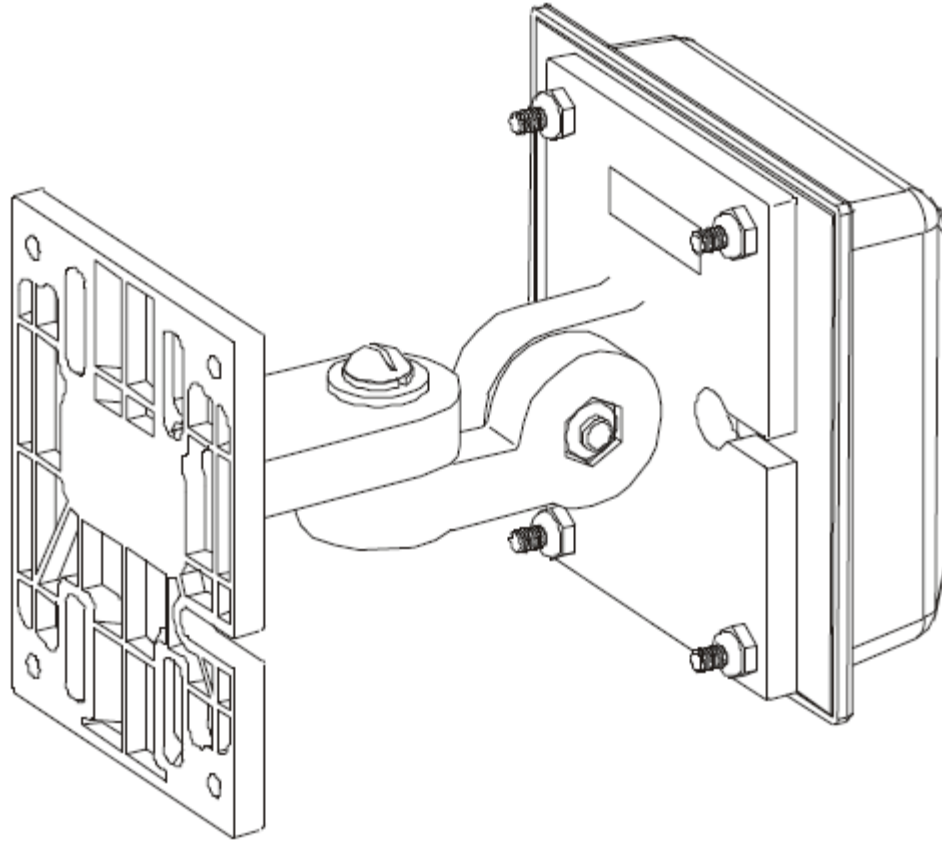


**Figure 93: Antenna mount attachment and antenna install to a vertical flat surface**

Callout	Description
A	Wall mount
B	Articulating arm
C	Antenna mount
D	¼ in. SS nylon hex nut
E	Machine screw
F	SS split lock washer
G	¼ in. flat washer
H	¼ in. - 20 SS hex nut
I	#8 plastic wall anchor
J	#8-18 × ¾ in. SS machine screws
K	3/16 in. diameter attachment hole for anchor

3. Using the wall mount as a template, mark and drill four attachment holes on a flat vertical surface. The attachment holes must be 3/16 in. in diameter.

4. Install four #8 plastic wall anchors into the attachment holes.
5. Attach the wall or pole mount to the flat surface using four #8-18 × ¾ in. SS machine screws.
6. Attach the articulating arm to the wall mount using a machine screw, SS split lock washer, ¼ in. flat washer, and ¼ in. – 20 SS hex nut.



**Figure 94: ML-2452-PNA7-01R antenna assembly**

## ML-2452-PNA7-01R Antenna Pole Install

### About This Task

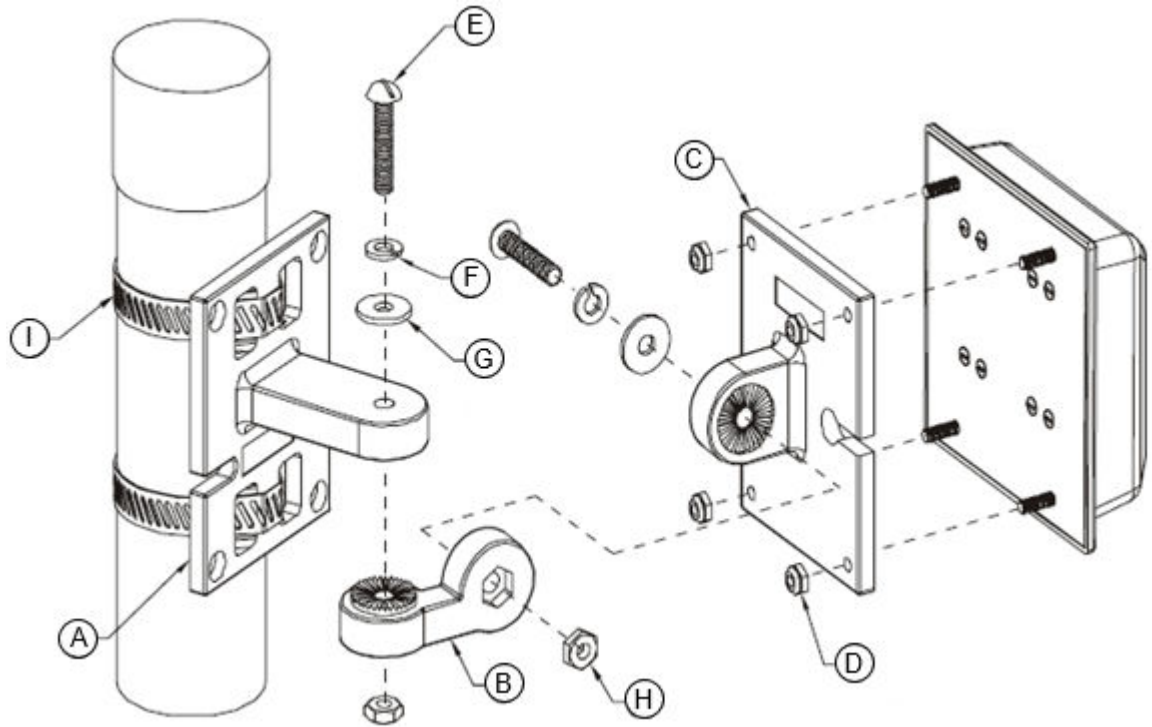
The ML-2452-PNA7-01R antenna is attached to poles up to 2 in. in diameter.

The following hardware is required for pole installation:

- One pole mount
- One articulating arm
- One antenna mount
- Four ¼ in. SS nylon hex nuts
- One machine screw
- One SS split lock washer
- One ¼ in. flat washer
- One ¼ in. – 20 SS hex nut
- Two hose clamps

### Procedure

1. Attach the antenna mount to the exposed studs on the antenna using four ¼ in. SS nylon hex nuts.
2. Attach the articulating arm to the antenna mount using the machine screw, SS split lock washer, ¼ in. flat washer, and ¼ in. – 20 SS hex nut.
3. Place the hose clamps through the cuts on the pole mount.
4. Attach the pole mount to a pole by tightening the screws on the hose clamps.

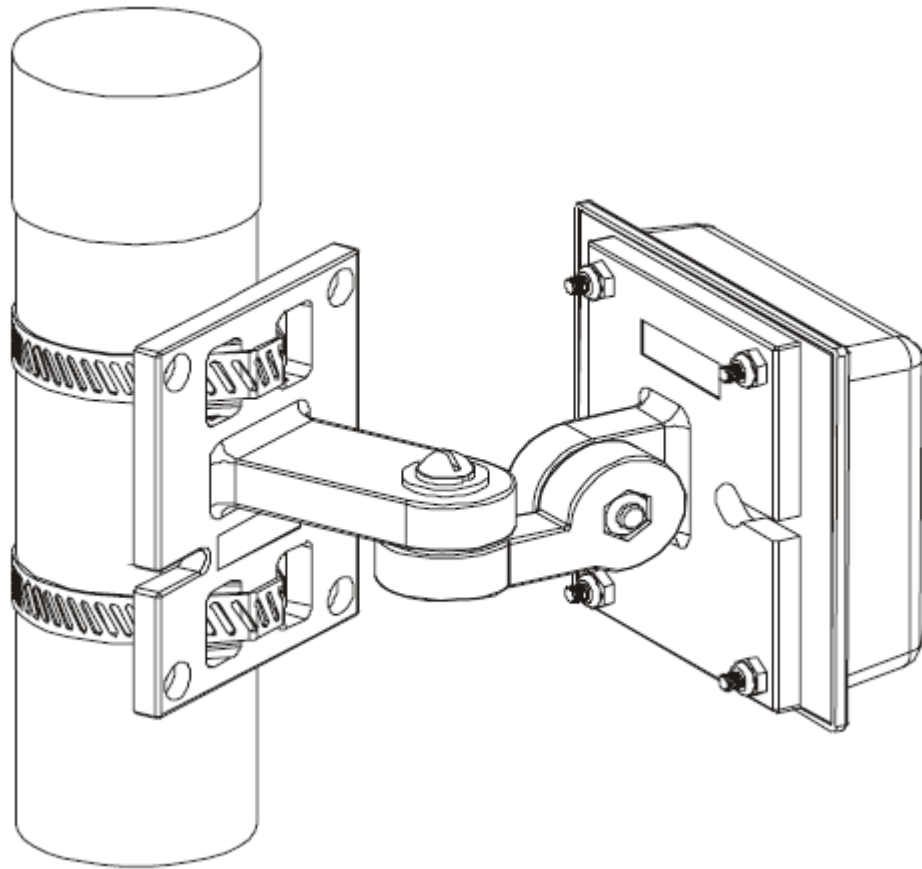


**Figure 95: ML-2452-PNA7-01R antenna being mounted on a pole using a wall or pole mount and hose clamps**

Callout	Description
A	Pole mount
B	Articulating arm
C	Antenna mount
D	¼ in. SS nylon hex nuts
E	Machine screw
F	SS split lock washer
G	¼ in. flat washer
H	¼ in. – 20 SS hex nut
I	Hose clamp



5. Attach the free end articulating arm to the wall or pole mount using a machine screw, SS split lock washer, ¼ in. flat washer, and ¼ in. – 20 SS hex nut.



**Figure 96: ML-2452-PNA7-01R antenna assembly mounted to a pole**

#### Related Topics

[ML-2452-PNA7-01R Antenna Specifications and Radiation Patterns](#) on page 55

## Install the AI-DQ04360S Antenna

### About This Task

The AI-DQ04360S antenna is mounted indoor or outdoor on a flat vertical surface, on a ceiling, or on a pole.



#### Note

If you mount the antenna outdoors, ensure that the antenna cables exit from the antenna bottom to prevent water intrusion and to provide a drain for internal moisture.

The antenna ships with the following mounting hardware:

- One mount interface bracket
- One mount base
- One wall bracket

- One ¼ - 20 × ½ in. cap screw
- One ¼ - 20 wing screw
- Two #10 × ¾ in. screws
- Two #10 × ½ in. screws
- One screen mesh washer
- One spherical washer
- One 3/16 allen wrench
- One jam nut

AI-DQ04360S antenna box contents:

- Antenna articulating pole mount kit
- Compliance tri-fold China WEEE URL card

You must provide the following hardware for installation:

- One #2 Phillips screwdriver
- One drill and drill bit
- One pencil
- Two hose clamps

## Vertical Surface Installation

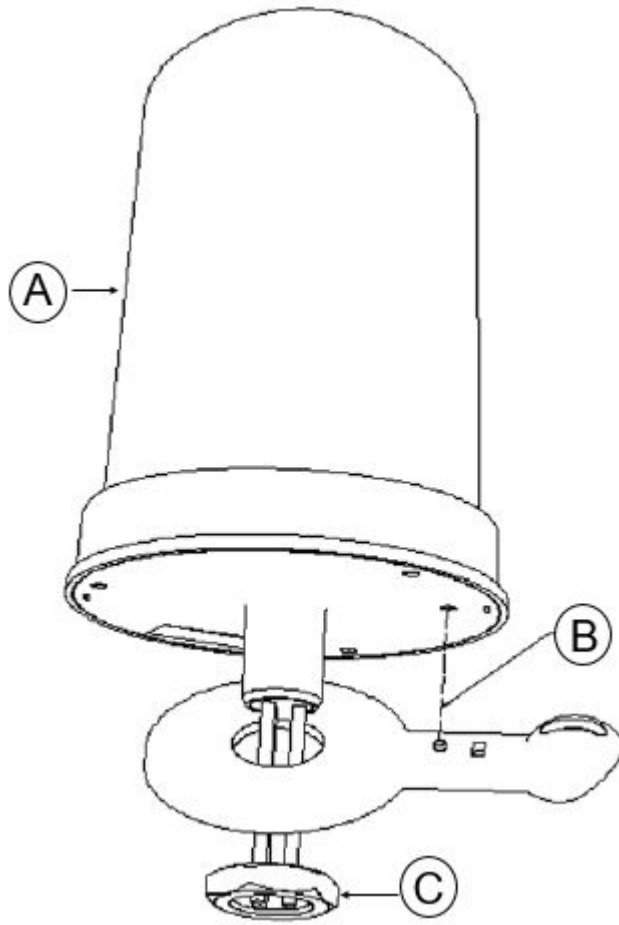
### **About This Task**

The following hardware components are required to mount the antenna on a vertical flat surface:

- One mount base
- One wall bracket
- One screen mesh washer
- One spherical washer
- One ¼ - 20 wing screw
- Two #10 × ¾ in. screws
- One mount interface bracket
- Two #10 × ½ in. screws

**Procedure**

1. Attach the mount interface bracket to the antenna using the jam nut.

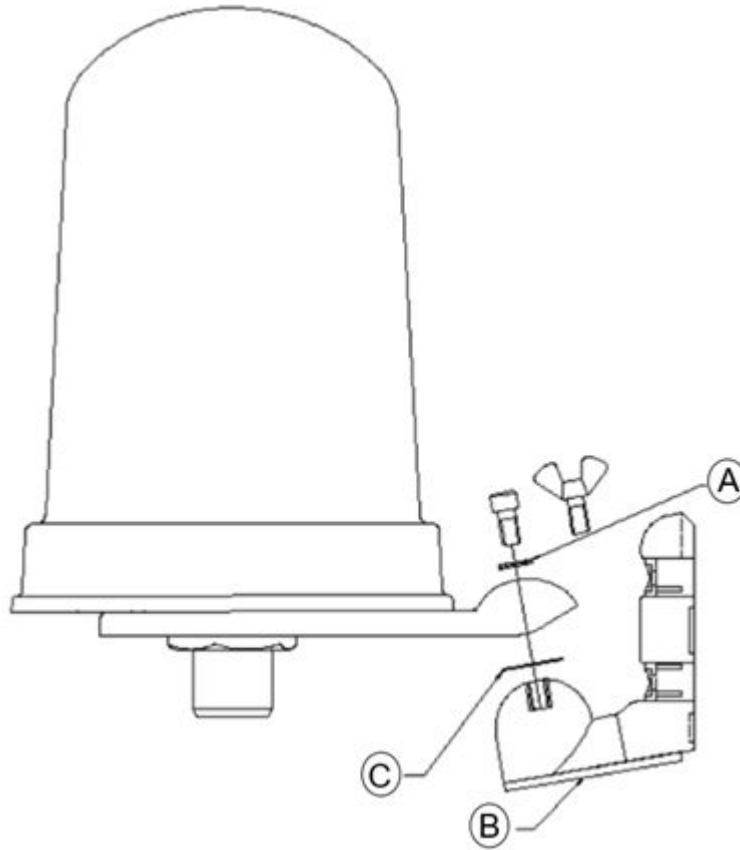


**Figure 97: Antenna mount interface bracket attached to the antenna**

Callout	Description
A	Antenna
B	Mount interface bracket alignment hole
C	Jam nut

2. Place the screen mesh washer between the mount interface bracket and the mount base.

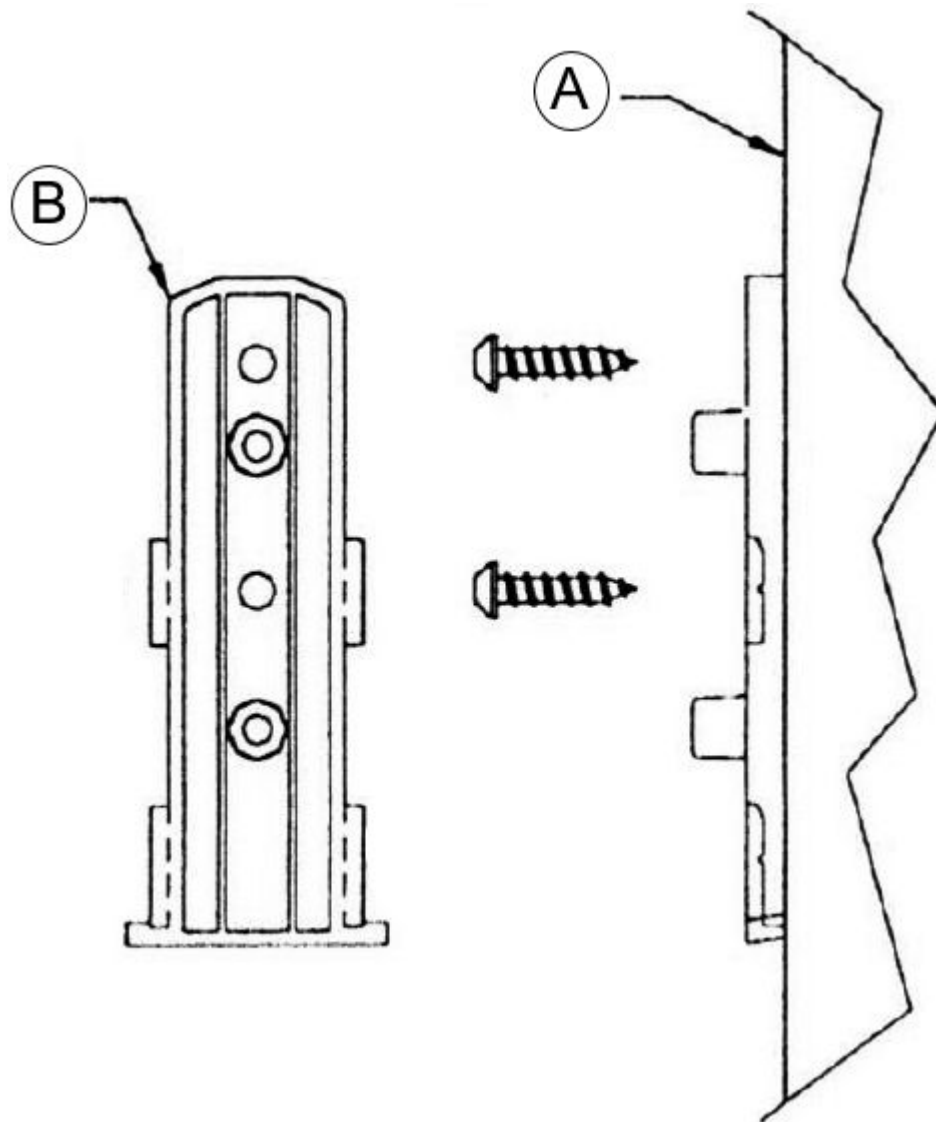
3. Attach the mount base to the mount interface bracket using the spherical washer and the ¼ - 20 wing screw.



Callout	Description
A	Spherical washer
B	Mount base
C	Screen mesh washer

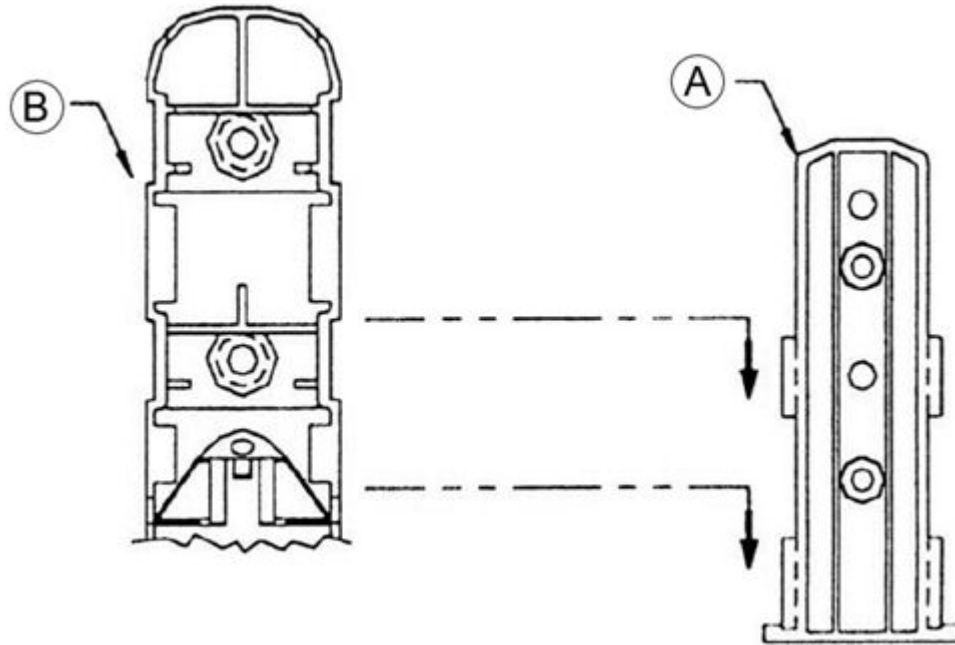
4. Use the wall bracket holes as a template, mark and drill two attachment holes on a flat vertical surface.

5. Attach the wall bracket to a wall using two #10 × ¾ in. screws.



Callout	Description
A	Flat vertical surface
B	Wall bracket

- Slide the mount base on the wall bracket, and secure it in place with two #10 × ½ in. screws.

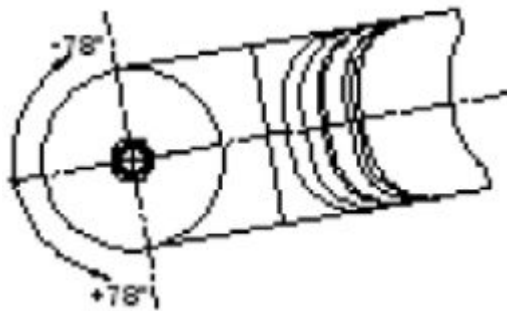


Callout	Description
A	Wall bracket
B	Mount base

- Adjust the antenna azimuth and elevation.

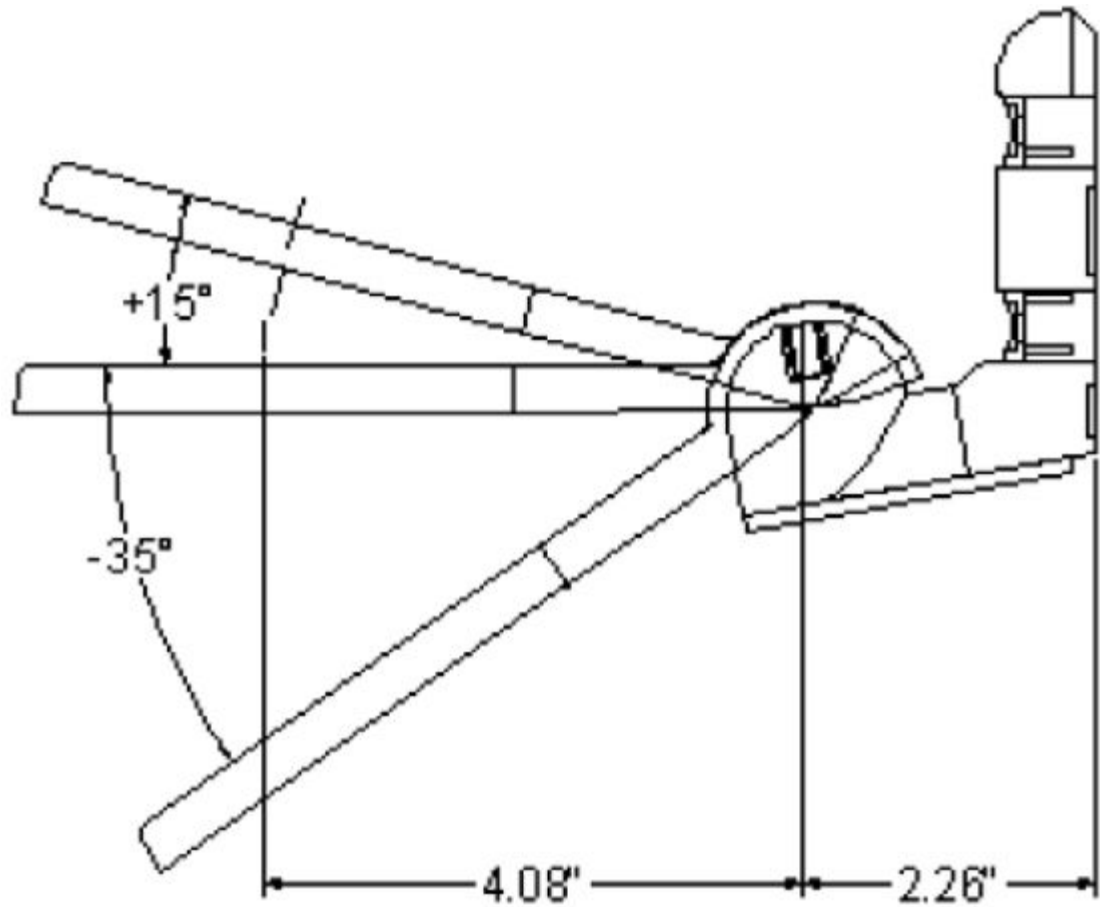
To adjust the azimuth and elevation, loosen the jam nut on the mount base.

Azimuth can be adjusted ±78°.



**Figure 98: Azimuth adjustment**

Elevation can be adjusted ±15° and -35°.



**Figure 99: Elevation adjustment**

## Ceiling Installation

### About This Task

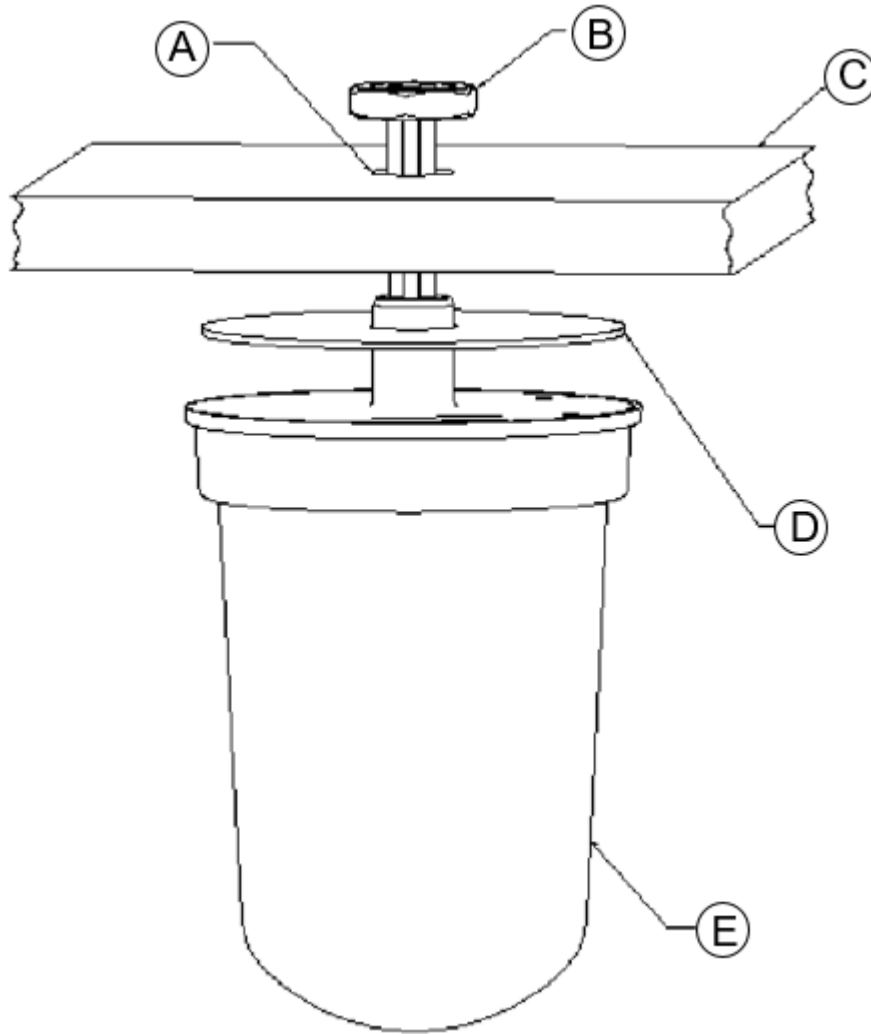
The following hardware is required for ceiling installation:

- One jam nut
- One rubber gasket

### Procedure

1. Drill a 1.25 in. diameter ceiling hole on a ceiling.
2. Fit the rubber gasket onto the bottom of the antenna.
3. Attach the antenna through the ceiling hole.

4. Thread the jam nut onto the antenna shaft, and tighten the jam nut.



**Figure 100: AI-DQ04360S antenna ceiling install**

Callout	Description
A	1.25 in. diameter ceiling hole
B	Jam nut
C	Ceiling
D	Rubber gasket
E	Antenna

## Pole Installation

### About This Task

The antenna is mounted on a pole using hose clamps.



The following hardware is required for pole installation:

- One mount base
- One mount interface bracket
- One screen mesh washer
- One jam nut
- One spherical washer
- One ¼ – 20 wing screw
- Two hose clamps

### Procedure

1. Follow step 1 to 3 from the [Vertical Surface Installation](#) on page 130 procedure.
2. Position the antenna, the mount base, and the hose clamps on a pole.
3. Tighten the hose clamps and secure the antenna onto a pole.
4. Adjust the antenna azimuth and elevation.

To adjust the antenna azimuth and elevation, loosen the jam nut on the mount base. For more information, see [Figure 98](#) on page 134 and [Figure 99](#) on page 135.

### Related Topics

[AI-DQ04360S Antenna Specifications and Radiation Patterns](#) on page 58

## Install the WS-AI-DQ05120, WS-AI-DE07025, or WS-AI-DE10055 Antenna

### About This Task

The WS-AI-DQ05120, WS-AI-DE07025, or the WS-AI-DE10055 antenna can be mounted to a pole using the pole mount kit. The pole mount kit is shipped with the following hardware:

- One antenna bracket attachment
- One elevation adjustable bracket
- One azimuth adjustable bracket
- Four ¼ in. – 20 × ¾ carriage bolts
- Six ¼ in. – 20 hex nuts
- Six ¼ in. – 20 spring lock washers
- Six ¼ in. – 20 flat washers
- Two pole clamps

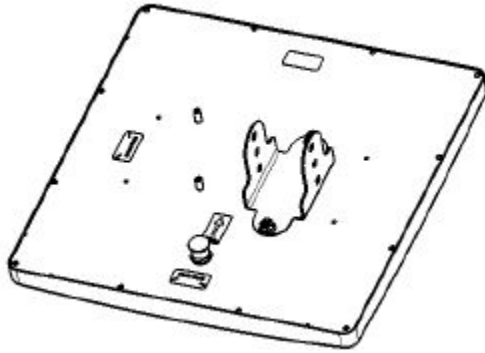
You must provide the following hardware:

- 7/16 in. wrench
- 8 mm nut driver or flat head screwdriver for hose clamps

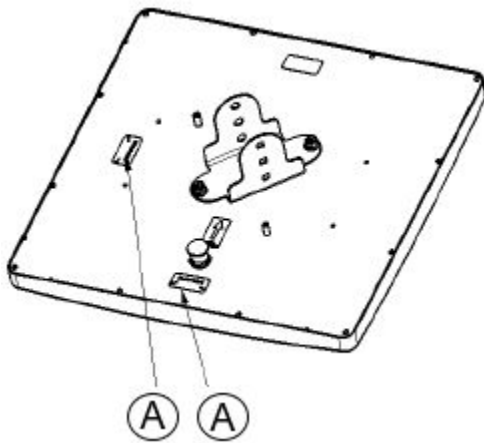


#### Note

The antenna bracket attachment fits in poles that are 1.63 in. – 2.30 in. in diameter. The antenna bracket attachment can be attached to a vertical pole, 45° slant pole, or to a horizontal pole.

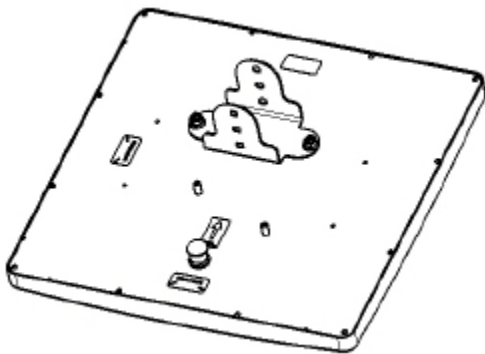


**Figure 101: Antenna bracket attachment position for vertical pole installation**



Callout	Description
A	Drain hole locations

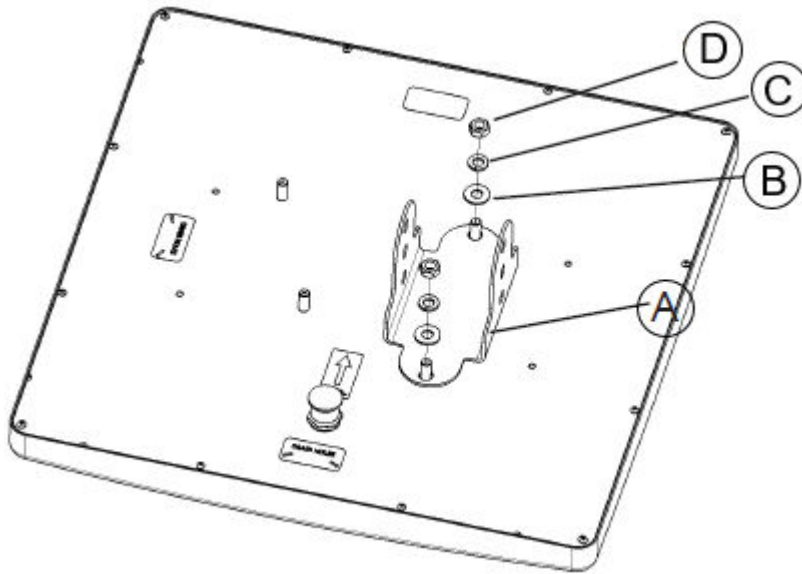
**Figure 102: Antenna bracket attachment position for 45° slant pole installation**



**Figure 103: Antenna bracket attachment position for horizontal pole installation**

**Procedure**

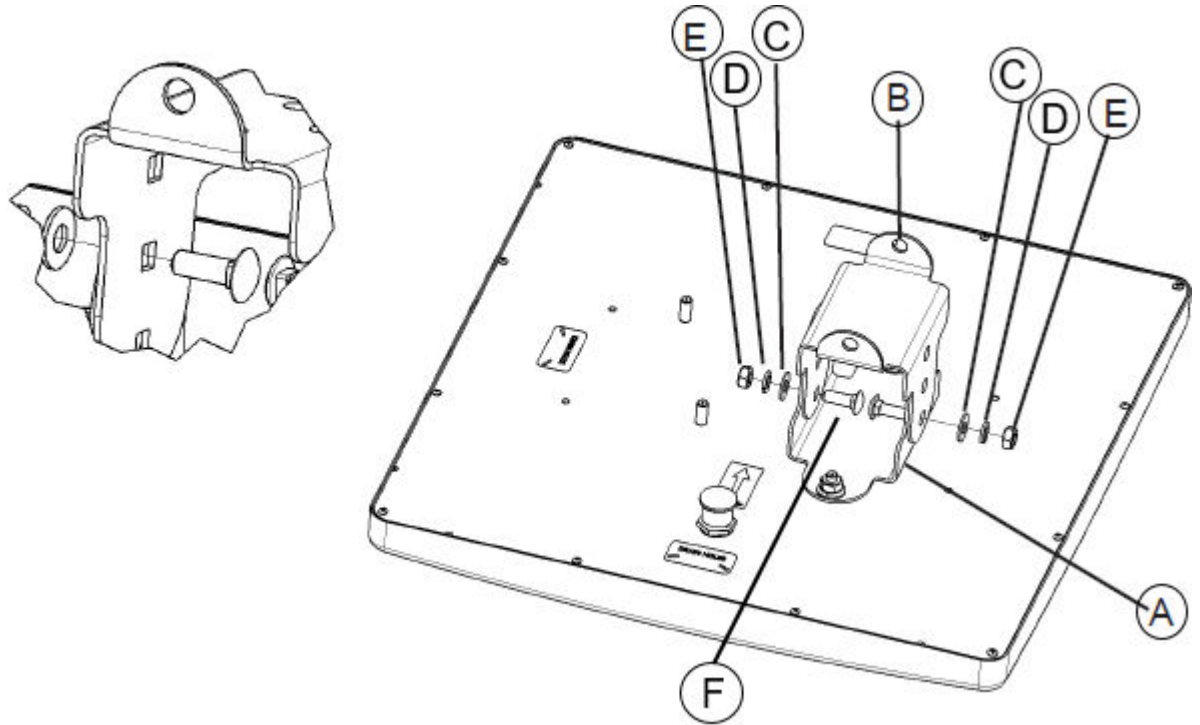
1. Attach antenna mount bracket to the back of the antenna using the flat washer, spring lock washer, and hex nut.



**Figure 104: Antenna bracket attachment procedure for vertical pole**

Callout	Description
A	Antenna bracket attachment
B	¼ in. – 20 flat washer
C	¼ in. – 20 spring lock washer
D	¼ in. – 20 hex nut

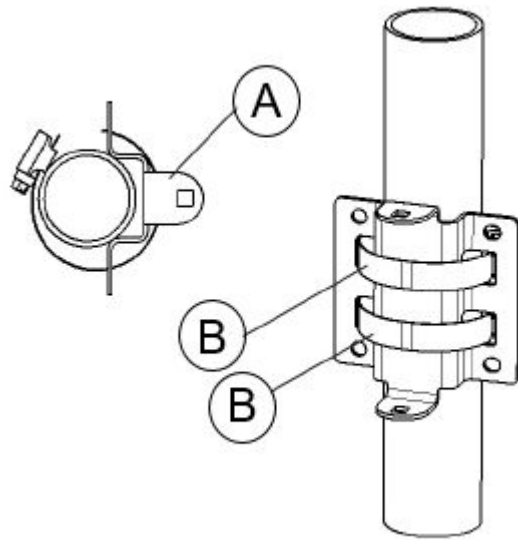
2. Tighten the bolt to a torque of 55 in. lbs.
3. Place one end of the elevation adjustable bracket inside the antenna attachment bracket, and the other end outside the attachment bracket, as shown in [Figure 105](#).  
Loosely secure the hardware.



**Figure 105: Antenna with antenna attachment bracket and elevation bracket**

Callout	Description
A	Antenna bracket attachment
B	Elevation bracket attachment
C	¼ in. – 20 flat washers
D	¼ in. – 20 spring lock washers
E	¼ in. – 20 hex nuts
F	¼ in. – 20× ¾ carriage bolt

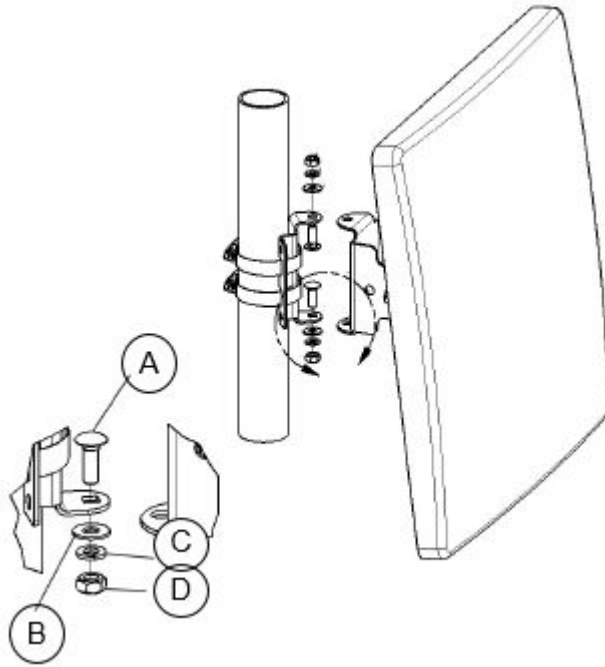
- Attach the azimuth adjustable bracket to a pole using two pole clamps.  
Tighten the pole clamps to a maximum torque.



**Figure 106: Antenna azimuth bracket attachment to a pole using pole clamps**

Callout	Description
A	Azimuth bracket attachment
B	Pole clamps

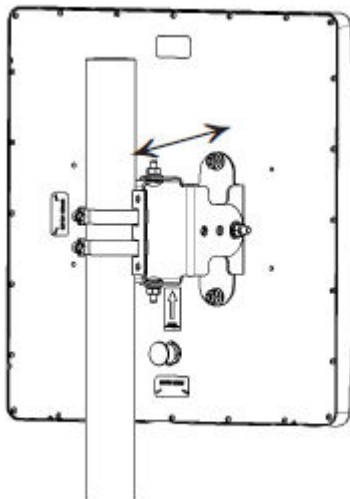
- Attach the antenna bracket attachment to the azimuth bracket attachment on the pole.



**Figure 107: Antenna assembly on a pole with azimuth bracket attachment**

Callout	Description
A	¼ in. – 20 × ¾ carriage bolts
B	¼ in. – 20 flat washers
C	¼ in. – 20 spring lock washers
D	¼ in. – 20 hex nuts

- Adjust the azimuth and elevation bracket angles, and tighten all hardware.



**Figure 108: Antenna assembly on a pole**

## Related Topics

[WS-AI-DQ05120 Antenna Specifications and Radiation Patterns](#) on page 61

[WS-AI-DE07025 Antenna Specifications and Radiation Patterns](#) on page 65

[WS-AI-DE10055 Antenna Specifications and Radiation Patterns](#) on page 69

## Install the WS-AO-DQ04360N Antenna

---

### About This Task

The WS-AI-DQ04360N antenna is installed outdoor on a flat vertical surface, on a ceiling, or on to a pole.

**Note**

Ensure that the antenna cables exit from the antenna bottom to prevent water intrusion and to provide a drain for internal moisture.

The antenna ships with the following hardware:

- One mount interface bracket
- One mount base
- One wall bracket
- One ¼ - 20 × ½ in. cap screw
- One ¼ - 20 wing screw
- Two #10 × ¾ in. screws
- Two #10 × ½ in. screws
- One screen mesh washer
- One spherical washer
- One 3/16 allen wrench
- One jam nut

WS-AI-DQ04360N antenna box contents:

- Antenna articulating pole mount kit
- Compliance tri-fold China WEEE URL card

You must provide the following hardware for installation:

- One #2 Phillips screwdriver
- One drill and drill bit
- One pencil
- Two hose clamps

## WS-AI-DQ04360N Antenna Vertical Surface Installation

### About This Task

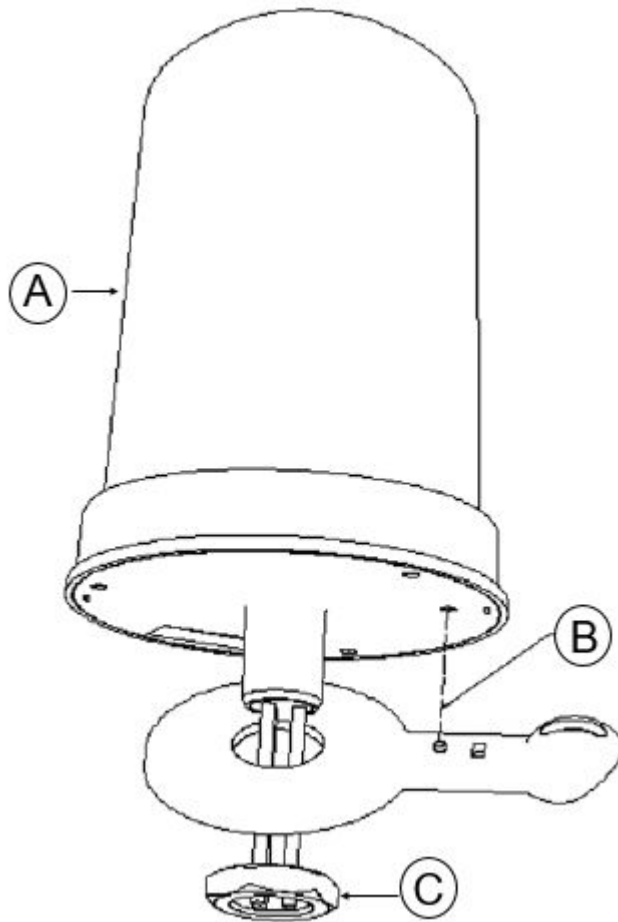
The following hardware components are required to mount the antenna on a vertical flat surface:

- One mount base
- One wall bracket

- One screen mesh washer
- One spherical washer
- One ¼ - 20 wing screw
- Two #10 × ¾ in. screws
- One mount interface bracket
- Two #10 × ½ in. screws

**Procedure**

1. Attach the mount interface bracket to the antenna using the jam nut.



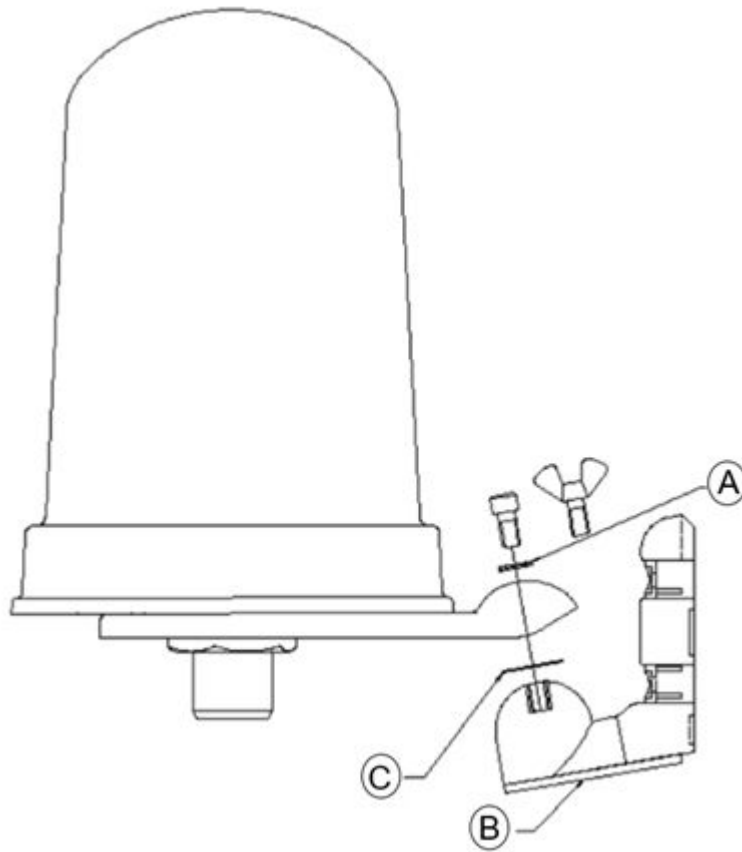
**Figure 109: Antenna mount interface bracket attached to the antenna**

Callout	Description
A	Antenna
B	Mount interface bracket alignment hole
C	Jam nut

2. Place the screen mesh washer between the mount interface bracket and the mount base.



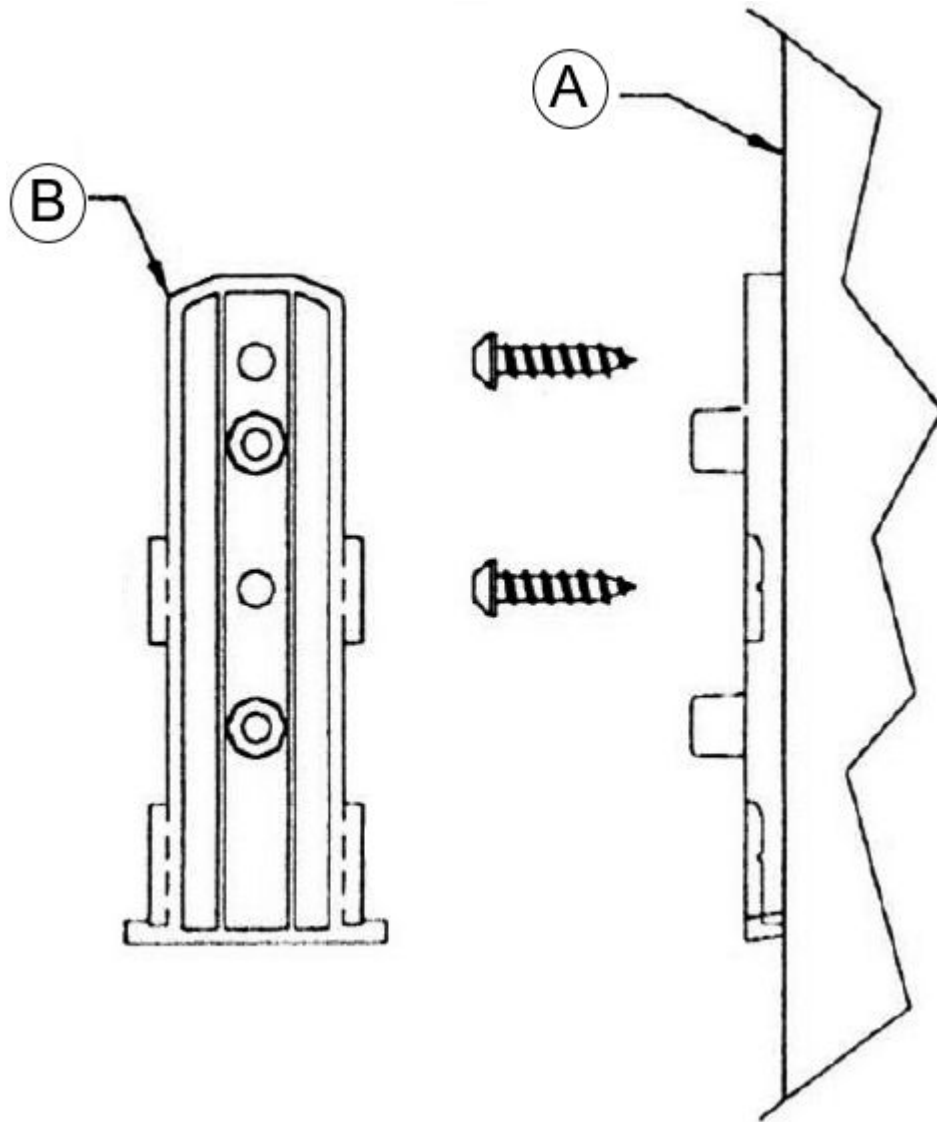
3. Attach the mount base to the mount interface bracket using the spherical washer and the ¼ - 20 wing screw.



Callout	Description
A	Spherical washer
B	Mount base
C	Screen mesh washer

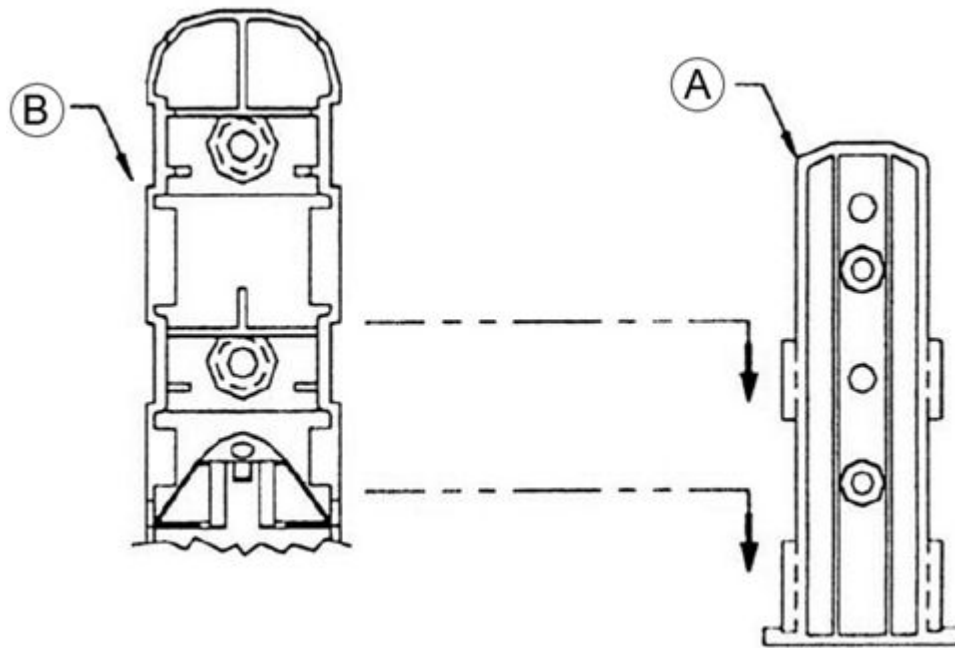
4. Use the wall bracket holes as a template, mark and drill two attachment holes on a flat vertical surface.

5. Attach the wall bracket to a wall using two #10 × ¾ in. screws.



Callout	Description
A	Flat vertical surface
B	Wall bracket

- Slide the mount base on the wall bracket, and secure it in place with two #10 × ½ in. screws.

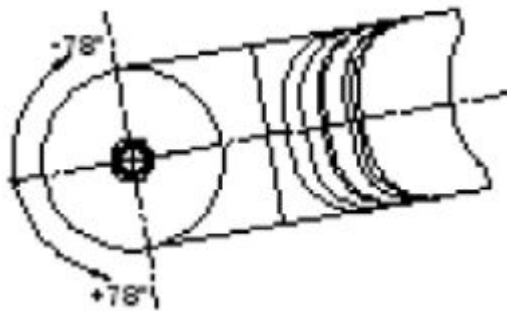


Callout	Description
A	Wall bracket
B	Mount base

- Adjust the antenna azimuth and elevation.

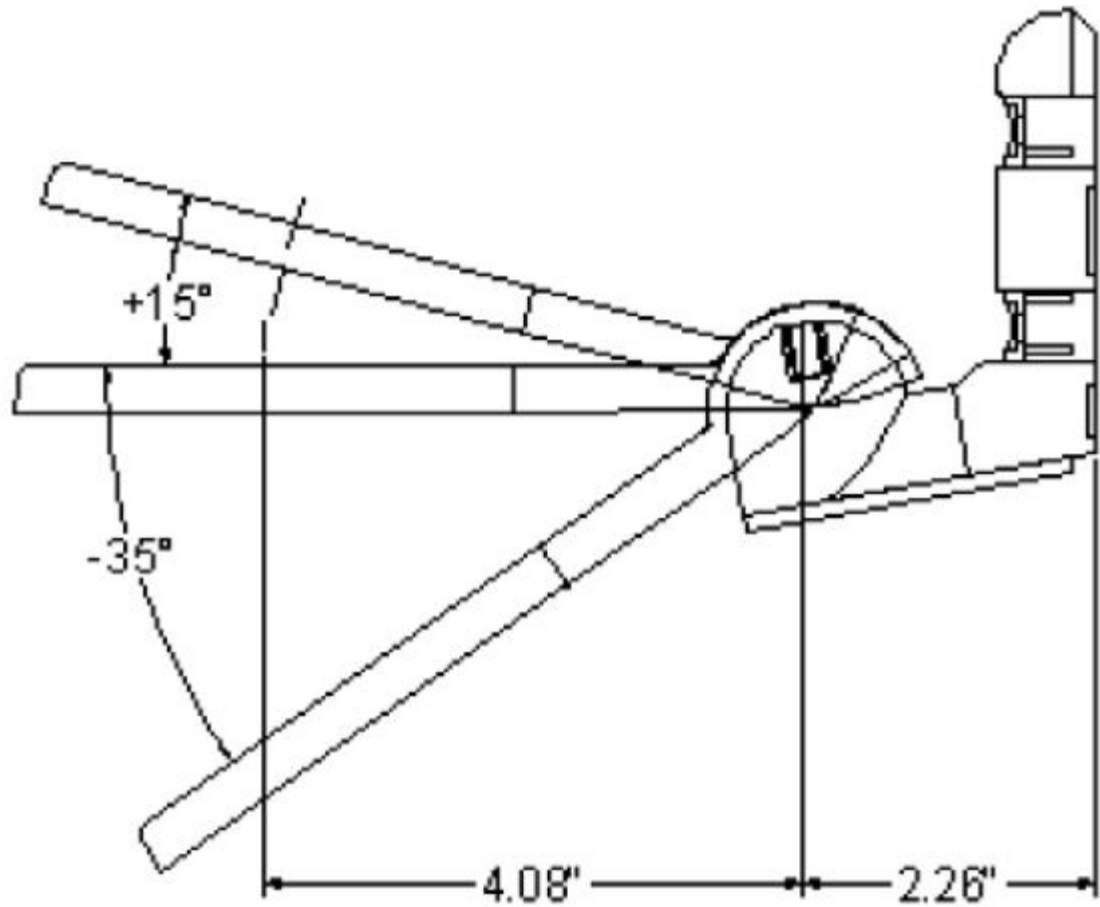
To adjust the azimuth and elevation, loosen the jam nut on the mount base.

Azimuth can be adjusted ±78°.



**Figure 110: Azimuth adjustment**

Elevation can be adjusted ±15° and -35°.



**Figure 111: Elevation adjustment**

## Ceiling Installation

### About This Task

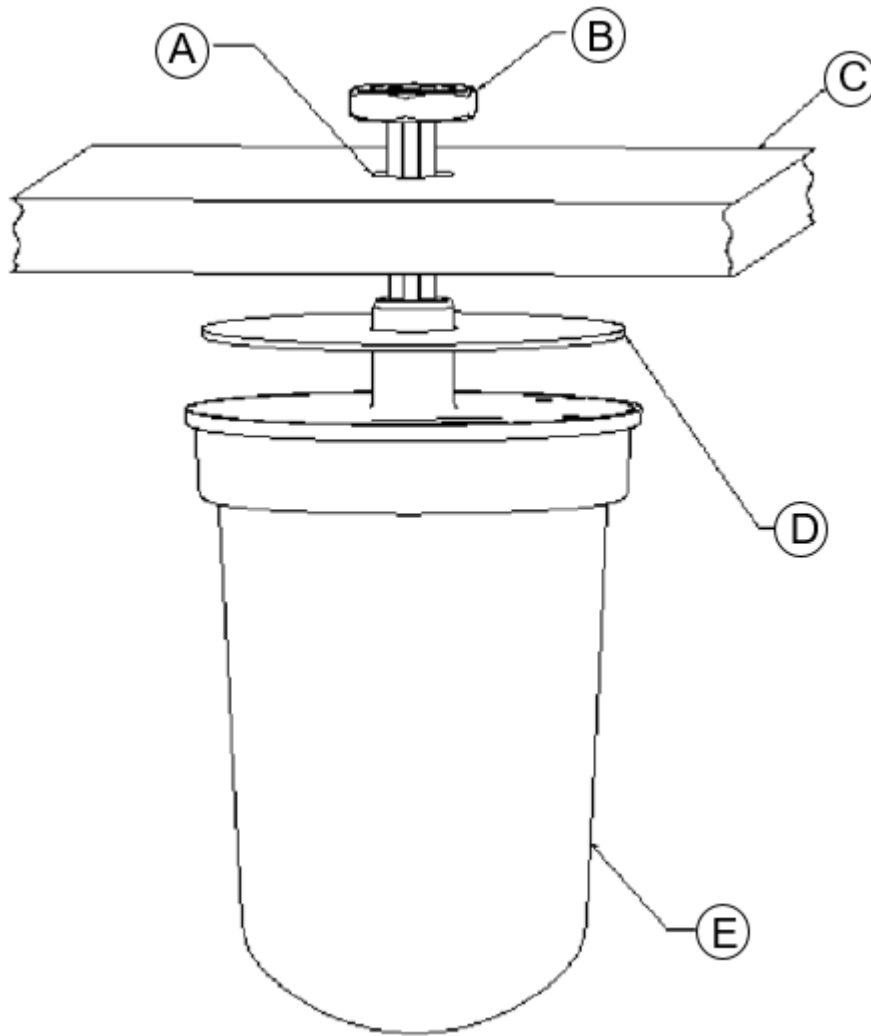
The following hardware is required for ceiling installation:

- One jam nut
- One rubber gasket

### Procedure

1. Drill a 1.25 in. diameter ceiling hole on a ceiling.
2. Fit the rubber gasket onto the bottom of the antenna.
3. Attach the antenna through the ceiling hole.

4. Thread the jam nut onto the antenna shaft, and tighten the jam nut.



**Figure 112: AI-DQ04360S antenna ceiling install**

Callout	Description
A	1.25 in. diameter ceiling hole
B	Jam nut
C	Ceiling
D	Rubber gasket
E	Antenna

## Pole Installation

### About This Task

The antenna is mounted on a pole using hose clamps.

The following hardware is required for pole installation:

- One mount base
- One mount interface bracket
- One screen mesh washer
- One jam nut
- One spherical washer
- One ¼ - 20 wing screw
- Two hose clamps

### **Procedure**

1. Follow step 1 to 3 from the [Vertical Surface Installation](#) on page 130 procedure.
2. Position the antenna, the mount base, and the hose clamps on a pole.
3. Tighten the hose clamps and secure the antenna onto a pole.
4. Adjust the antenna azimuth and elevation.

To adjust the antenna azimuth and elevation, loosen the jam nut on the mount base. For more information, see [Figure 98](#) on page 134 and [Figure 99](#) on page 135.

### Related Topics

[WS-AO-DQ04360N Antenna Specifications and Radiation Patterns](#) on page 73



# Index

---

## A

- access point support
  - external antenna 19, 21, 22
- AI-DQ04360S antenna
  - specifications
    - electrical specifications 58, 60
    - mechanical specifications 58, 60
    - radiation patterns 58, 60
    - technical specifications 58, 60
- AI-DQ04360S antenna install
  - indoor install
  - outdoor install
    - ceiling install 129
    - pole install 129
  - vertical surface install 129
- antenna cables specifications
  - indoor antenna cables specifications 94, 95
  - outdoor antenna cables specifications 94, 95
- antenna compatibility 18
- antenna connectors
  - N-type standard male connector 8
  - reverse polarity SMA female (RP-SMA-F) 8
  - reverse polarity SMA male (RP-SMA-M) 8
- antenna installation best practices
  - antenna direction 99
  - antenna location 99
  - building material 99
- antenna installation information 99
- antenna location criteria
  - antenna location requirements
    - access point placement 13, 15
    - antenna height 13, 15
    - grounding system 13, 15
    - lightning protection 13, 15
  - line of sight 13, 15
- antenna matrix 18
- antenna selection
  - antenna connector types 8
  - antenna selection criteria 8
- antenna selection criteria
  - antenna pattern 10–12
  - antenna performance 10–12
  - antenna type 10–12
  - indoor antenna 10–12
  - outdoor antenna 10–12
- AP310e external antenna connectors 19, 21, 22
- AP410e external antenna connectors 19, 21, 22
- AP460e external antenna connectors 19, 21, 22

- AP505i antenna radiation patterns 78
- AP510e external antenna connectors 19, 21, 22
- AP510i antenna radiation patterns 82
- AP560i antenna radiation patterns 88

## C

- cable options
  - indoor cables 17
  - outdoor cables 17
- compatibility matrix 18
- conventions
  - notice icons v
  - text v

## D

- documentation
  - feedback vi
  - location vii

## E

- external antenna radiation patterns 24
- external antenna specifications 24

## I

- internal antenna radiation patterns 77

## M

- ML-2452-APA2-01 and ML-2452-APA2-02 antenna
  - radiation patterns
    - 2G radio radiation pattern 24, 26
    - 5G radio radiation pattern 24, 26
  - specifications
    - electrical specifications 24, 26
    - mechanical specifications 24, 26
    - technical specifications 24, 26
- ML-2452-APA2-01 antenna install 100
- ML-2452-APA2-02 antenna install 100
- ML-2452-HPA5-036 antenna
  - radiation patterns 28, 30
  - specifications
    - electrical specifications 28, 30
    - mechanical specifications 28, 30
    - technical specifications 28, 30
- ML-2452-HPA5-036 antenna install 101
- ML-2452-HPA6-01 antenna

ML-2452-HPA6-01 antenna (*continued*)  
 radiation patterns 33, 35  
 specifications  
   electrical specifications 33, 35  
   mechanical specifications 33, 35  
   technical specifications 33, 35

ML-2452-HPA6-01 antenna install 110

ML-2452-HPAG4A6-01 antenna  
 radiation patterns 36, 38  
 specifications  
   electrical specifications 36, 38  
   mechanical specifications 36, 38  
   technical specifications 36, 38

ML-2452-HPAG4A6-01 antenna install 110

ML-2452-HPAG5A8-01 antenna  
 radiation patterns  
   azimuth patterns 39, 41  
   elevation patterns 39, 41  
 specifications  
   electrical specifications 39, 41  
   mechanical specifications 39, 41  
   technical specifications 39, 41

ML-2452-HPAG5A8-01 antenna install 111

ML-2452-PNA5-01R antenna  
 radiation patterns 49, 51  
 specifications  
   electrical specifications 49, 51  
   mechanical specifications 49, 51  
   technical specifications 49, 51

ML-2452-PNA5-01R antenna install 115

ML-2452-PNA7-01R antenna  
 radiation patterns 55, 57  
 specifications  
   electrical specifications 55, 57  
   mechanical specifications 55, 57  
   technical specifications 55, 57

ML-2452-PNA7-01R antenna install 125

ML-2452-PTA4M4-036 antenna  
 radiation patterns 43, 44  
 specifications  
   electrical specifications 43, 44  
   mechanical specifications 43, 44  
   technical specifications 43, 44

ML-2452-SEC6M4-036 antenna  
 radiation patterns 53, 54  
 specifications  
   electrical specifications 53, 54  
   mechanical specifications 53, 54  
   technical specifications 53, 54

ML-2452-SEC6M4-036 antenna install 122

## O

Open Source Declaration vii

## S

site preparation  
 antenna location criteria 8

support, see technical support

## T

technical support  
 contacting vi, vii

## W

WS-AI-DE07025 antenna  
 radiation patterns 65, 67  
 specifications  
   electrical specifications 65, 67  
   mechanical specifications 65, 67  
   technical specifications 65, 67

WS-AI-DE07025 antenna install 137

WS-AI-DE10055 antenna  
 specifications  
   electrical specifications 69, 71  
   mechanical specifications 69, 71  
   radiation patterns 69, 71  
   technical specifications 69, 71

WS-AI-DE10055 antenna install 137

WS-AI-DQ04360N antenna install  
 outdoor install  
   ceiling install 143  
   pole install 143  
   vertical surface install 143

WS-AI-DQ05120 antenna  
 radiation patterns 61, 63  
 specifications  
   electrical specifications 61, 63  
   mechanical specifications 61, 63  
   technical specifications 61, 63

WS-AI-DQ05120 antenna install 137

WS-AO-DQ04360N antenna  
 specifications  
   electrical specifications 73, 75  
   mechanical specifications 73, 75  
   technical specifications 73, 75